

Name	Signatur	Datum	Artikelnummer	Oberfläche: Elektropoliert
Ch. Höfig	CH	13.06.2018	10180003	
Werkstoff: 1.4401/04 (X5CrNiMo17-12-2)			Hersteller  Qualitätsprodukte aus Edelstahl, Stahl und Schmiedeeisen	Blattformat A4
Gewicht 0,085 kg			Massstab: 1:2,5 Version: 1	Blatt 1 von 12

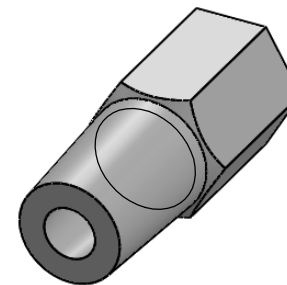

Name	Signatur	Datum	Artikelnummer	Oberfläche: Geschliffen Korn 240
Ch. Höfig	CH	13.06.2018	10180003 Teil1	
Werkstoff:		Hersteller		Blattformat
1.4401/04 (X5CrNiMo17-12-2)		 Qualitätsprodukte aus Edelstahl, Stahl und Schmiedeeisen		A4
Gewicht 0,015 kg		Massstab: 1,5:1	Version: 1	Blatt 2 von 12

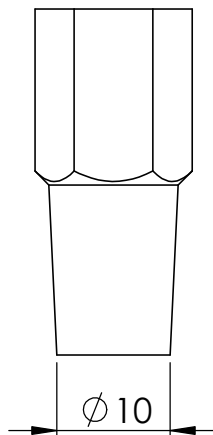
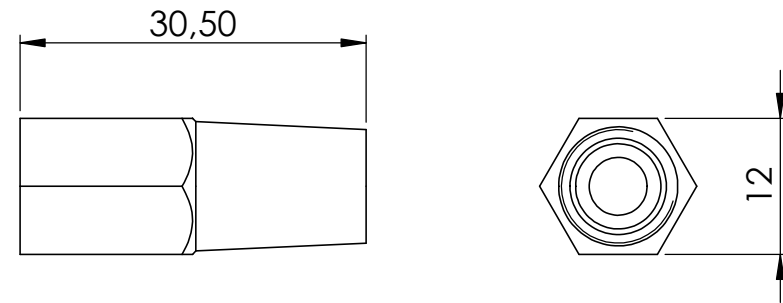
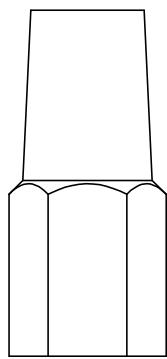
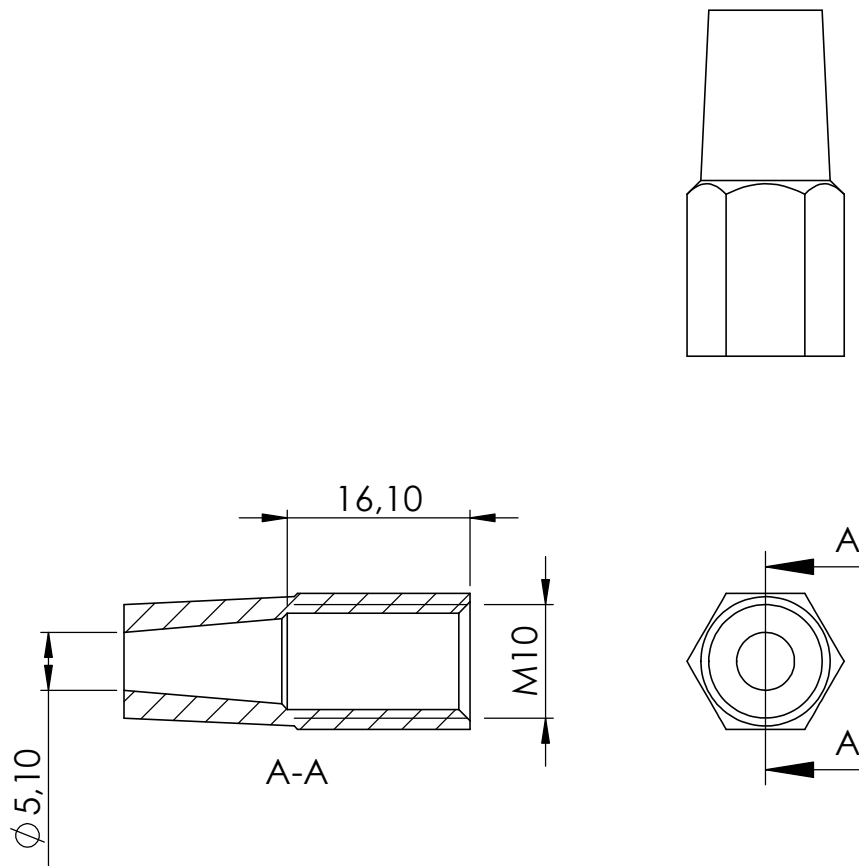
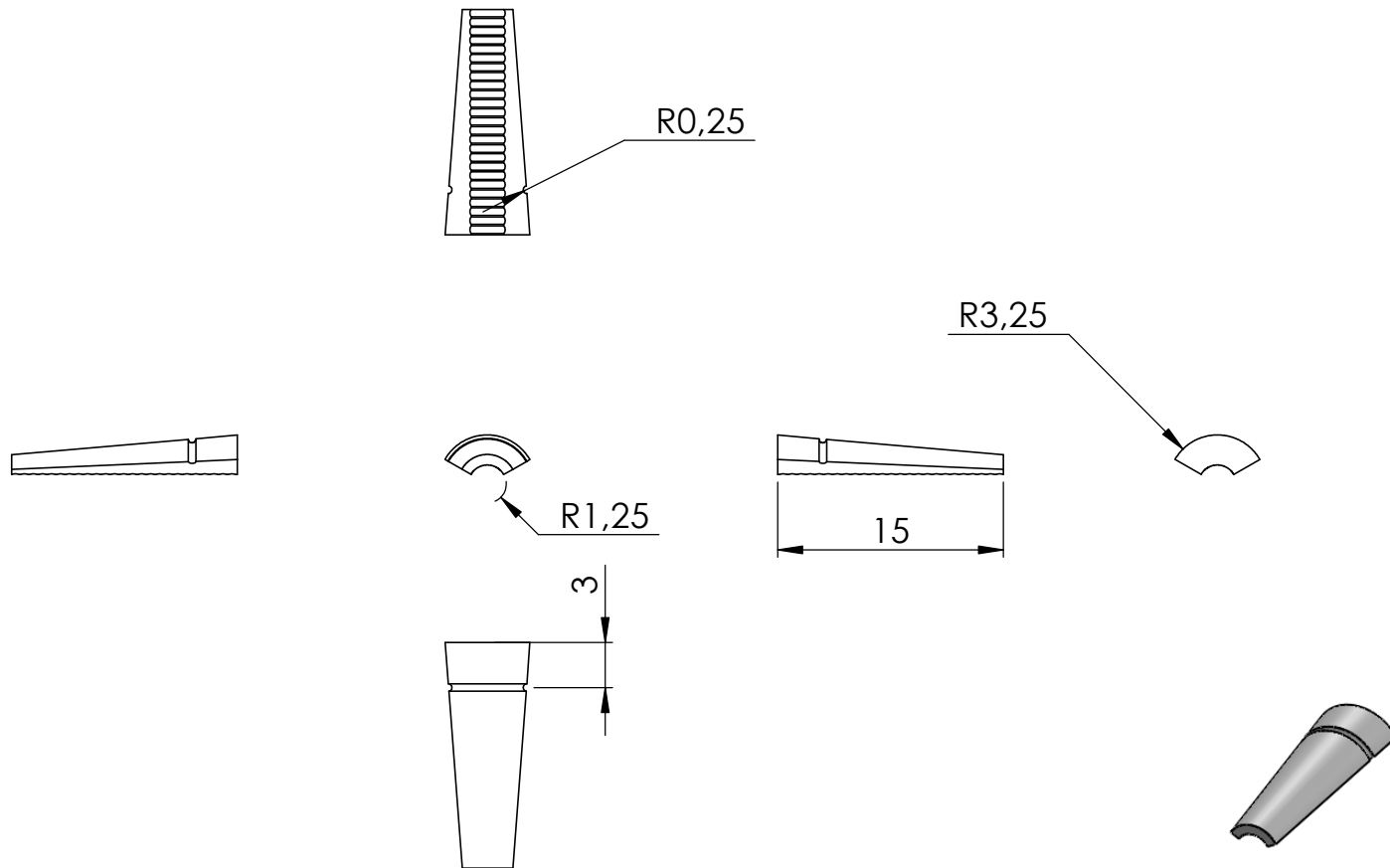

Name	Signatur	Datum	Artikelnummer	Oberfläche: Roh
Ch. Höfig	CH	13.06.2018	10180003 Teil2	
Werkstoff: 1.4401/04 (X5CrNiMo17-12-2)			Hersteller	Blattformat
			 Feldmann GmbH <small>Qualitätsprodukte aus Edelstahl, Stahl und Schmiedeeisen</small>	
Gewicht 0,001 kg			Massstab: 2:1	Version: 1
			Blatt 3 von 12	
			A4	

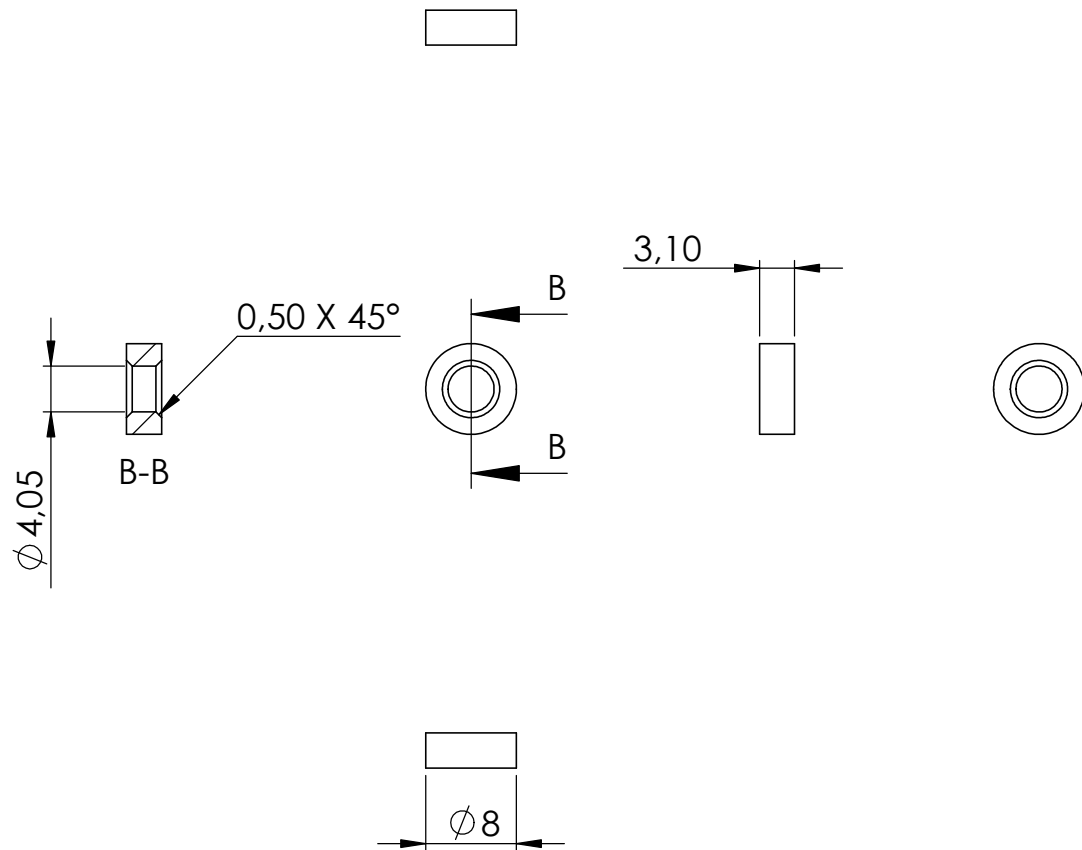

Name	Signatur	Datum	Artikelnummer	Oberfläche: Roh
Ch. Höfig	CH	13.06.2018	10180003 Teil3	
Werkstoff: Messing			Hersteller	Blattformat
			 Feldmann GmbH Qualitätsprodukte aus Edelstahl, Stahl und Schmiedeeisen	A4
Gewicht 0,001 kg			Massstab: 1,5:1 Version: 1	Blatt 4 von 12

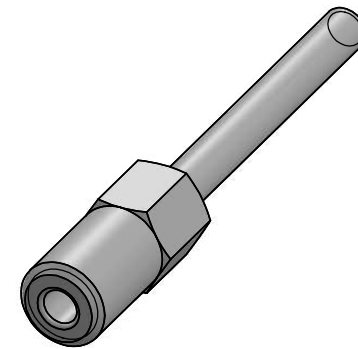
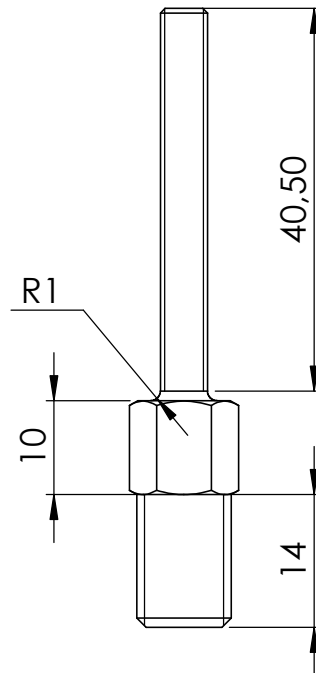
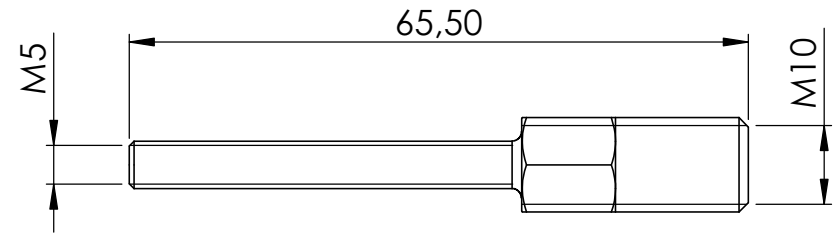
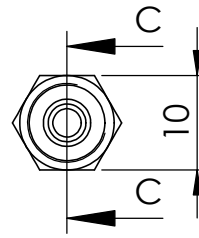
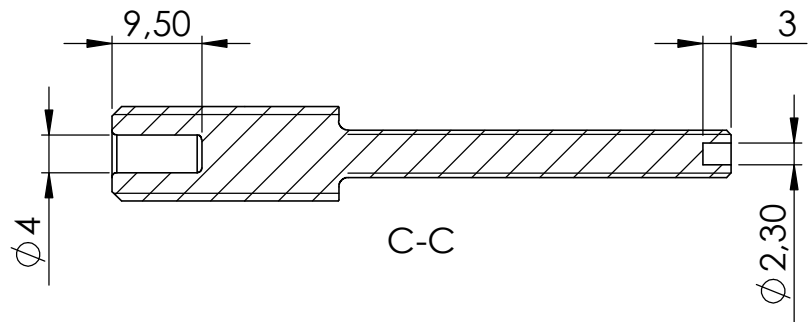

Name	Signatur	Datum	Artikelnummer	Oberfläche: Elektropoliert
Ch. Höfig	CH	13.06.2018	10180003 Teil4	
Werkstoff: 1.4401/04 (X5CrNiMo17-12-2)			Hersteller  Qualitätsprodukte aus Edelstahl, Stahl und Schmiedeeisen	Blattformat A4
Gewicht 0,021 kg			Massstab: 1,25:1 Version: 1	Blatt 5 von 12

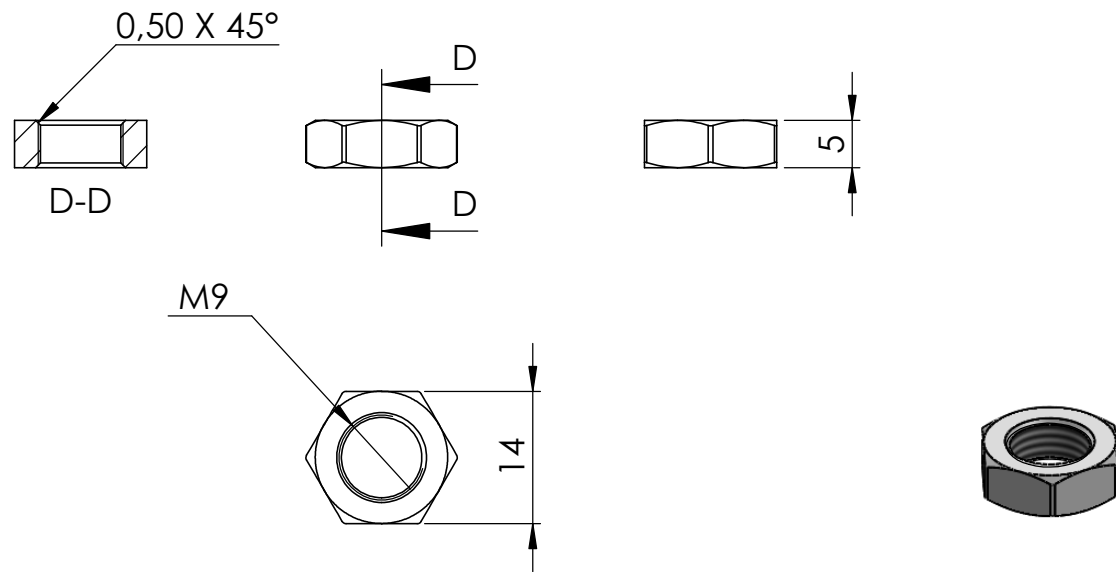

Name	Signatur	Datum	Artikelnummer	Oberfläche: Roh
Ch. Höfig	CH	13.06.2018	10180003 Teil5	
Werkstoff: 1.4401/04 (X5CrNiMo17-12-2)			Hersteller	Blattformat
			 <small>Qualitätsprodukte aus Edelstahl, Stahl und Schmiedeeisen</small>	
Gewicht 0,004 kg			Massstab: 1,25:1	Version: 1
			Blatt 6 von 12	

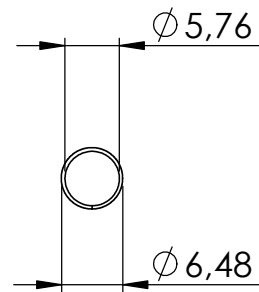

Name	Signatur	Datum	Artikelnummer	Oberfläche: Roh
Ch. Höfig	CH	13.06.2018	10180003 Teil6	
Werkstoff: 1.4401/04 (X5CrNiMo17-12-2)			Hersteller	Blattformat
			 Feldmann GmbH Qualitätsprodukte aus Edelstahl, Stahl und Schmiedeeisen	A4
Gewicht 0,000 kg			Maßstab: 1,25:1 Version: 1	Blatt 7 von 12

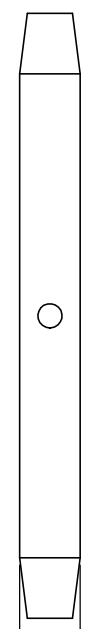
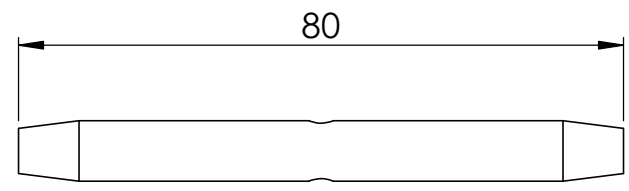
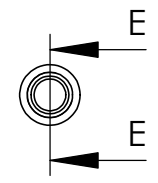
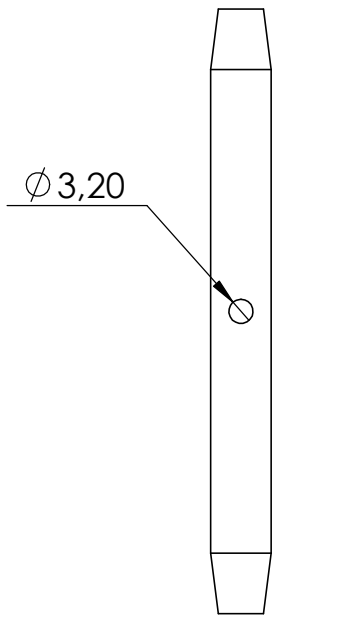
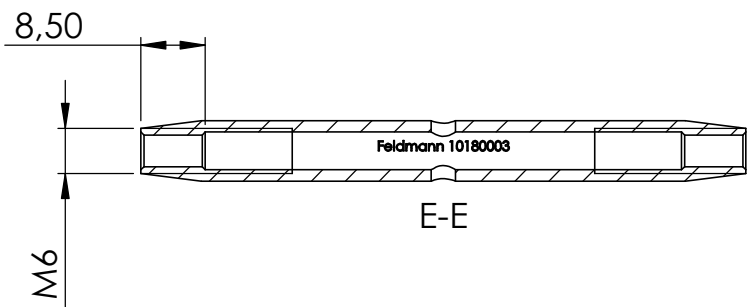

Name	Signatur	Datum	Artikelnummer	Oberfläche: Elektropoliert
Ch. Höfig	CH	13.06.2018	10180003 Teil7	
Werkstoff: 1.4401/04 (X5CrNiMo17-12-2)			Hersteller	Blattformat
			 Qualitätsprodukte aus Edelstahl, Stahl und Schmiedeeisen	A4
Gewicht 0,019 kg			Massstab: 1:1	Version: 1
			Blatt 8 von 12	

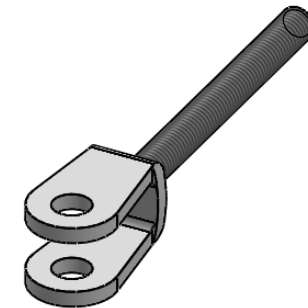
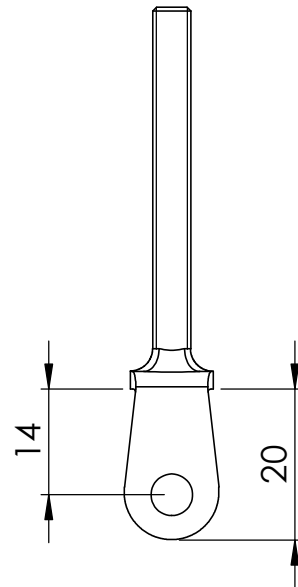
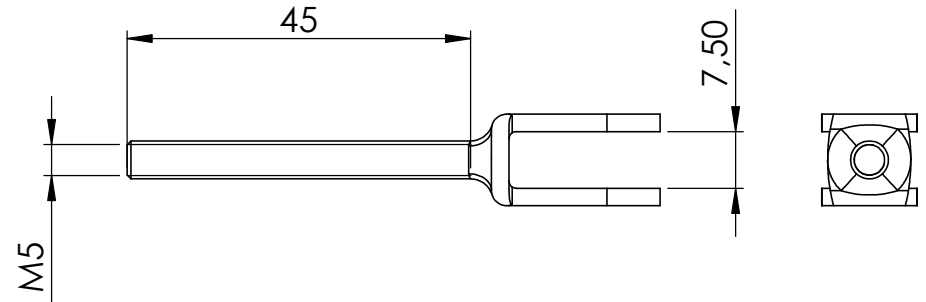
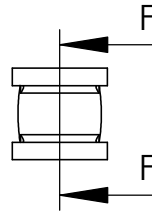
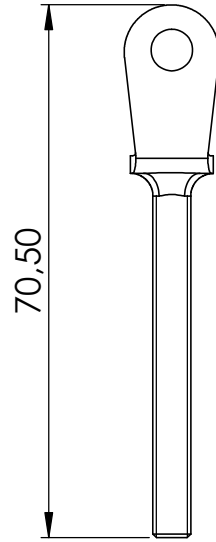
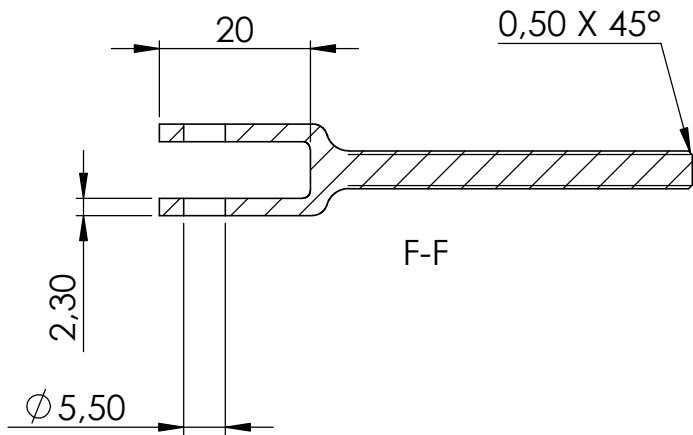

Name	Signatur	Datum	Artikelnummer	Oberfläche: Elektropoliert
Ch. Höfig	CH	13.06.2018	10180003 Teil8	
Werkstoff:		Hersteller		Blattformat
1.4401/04 (X5CrNiMo17-12-2)		 Feldmann GmbH <small>Qualitätsprodukte aus Edelstahl, Stahl und Schmiedeeisen</small>		A4
Gewicht 0,017 kg		Massstab: 1:1	Version: 1	Blatt 9 von 12

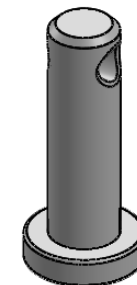
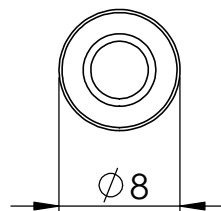
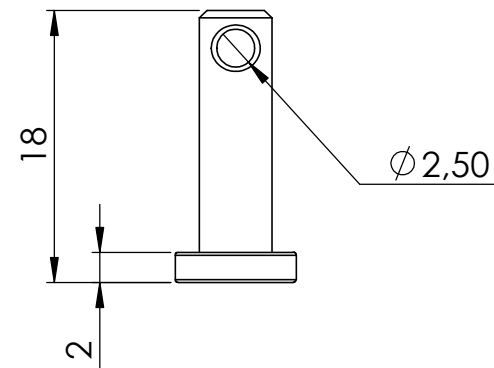
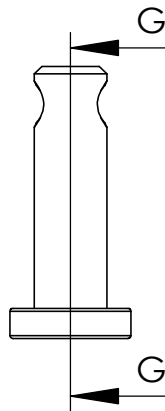
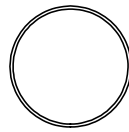
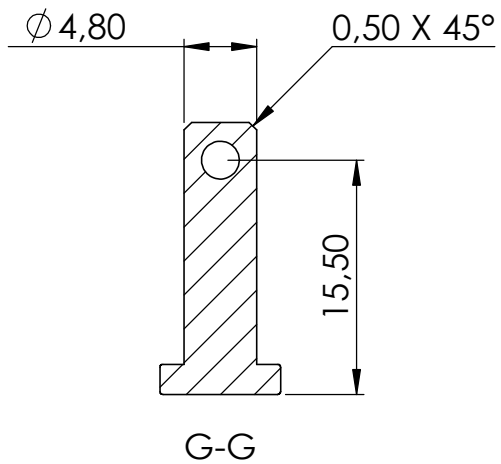

Name	Signatur	Datum	Artikelnummer	Oberfläche: Roh
Ch. Höfig	CH	13.06.2018	10180003 Teil9	
Werkstoff: 1.4401/04 (X5CrNiMo17-12-2)			Hersteller	Blattformat
			 <small>Qualitätsprodukte aus Edelstahl, Stahl und Schmiedeeisen</small>	
Gewicht 0,003 kg			Massstab: 2:1	Version: 1
			Blatt 10 von 12	

A4

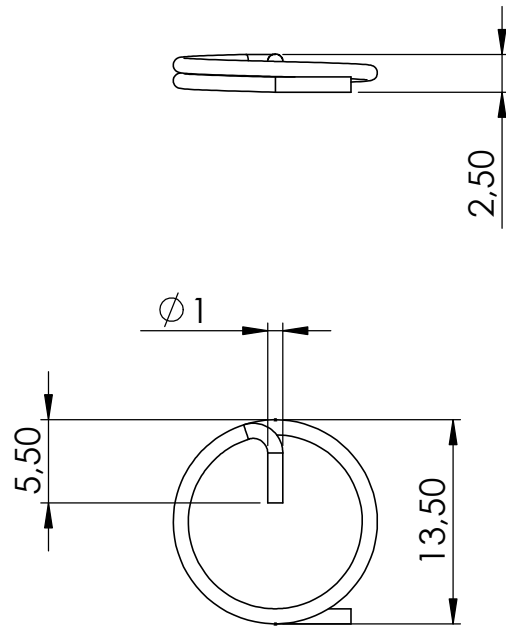

Name	Signatur	Datum	Artikelnummer	Oberfläche: Elektropoliert
Ch. Höfig	CH	13.06.2018	10180003 Teil7	
Werkstoff: 1.4401/04 (X5CrNiMo17-12-2)			Hersteller	Blattformat
			 <small>Qualitätsprodukte aus Edelstahl, Stahl und Schmiedeeisen</small>	
Gewicht 0,000 kg			Maßstab: 2:1	Version: 1
			Blatt 11 von 12	

A4

POS-NR.	BENENNUNG	MENGE
1	10180003 Teil7	1
2	10180003 Teil4	1
3	10180003 Teil5	1
4	58321-240-5	1
5	58321-240-5-L	1
6	10180003 Teil1	1
7	10180003 Teil3	1
8	10180003 Teil2	3
9	10180003 Teil6	1
10	10180003 Teil8	1
11	10180003 Teil9	1
12	10180003 Teil7	1

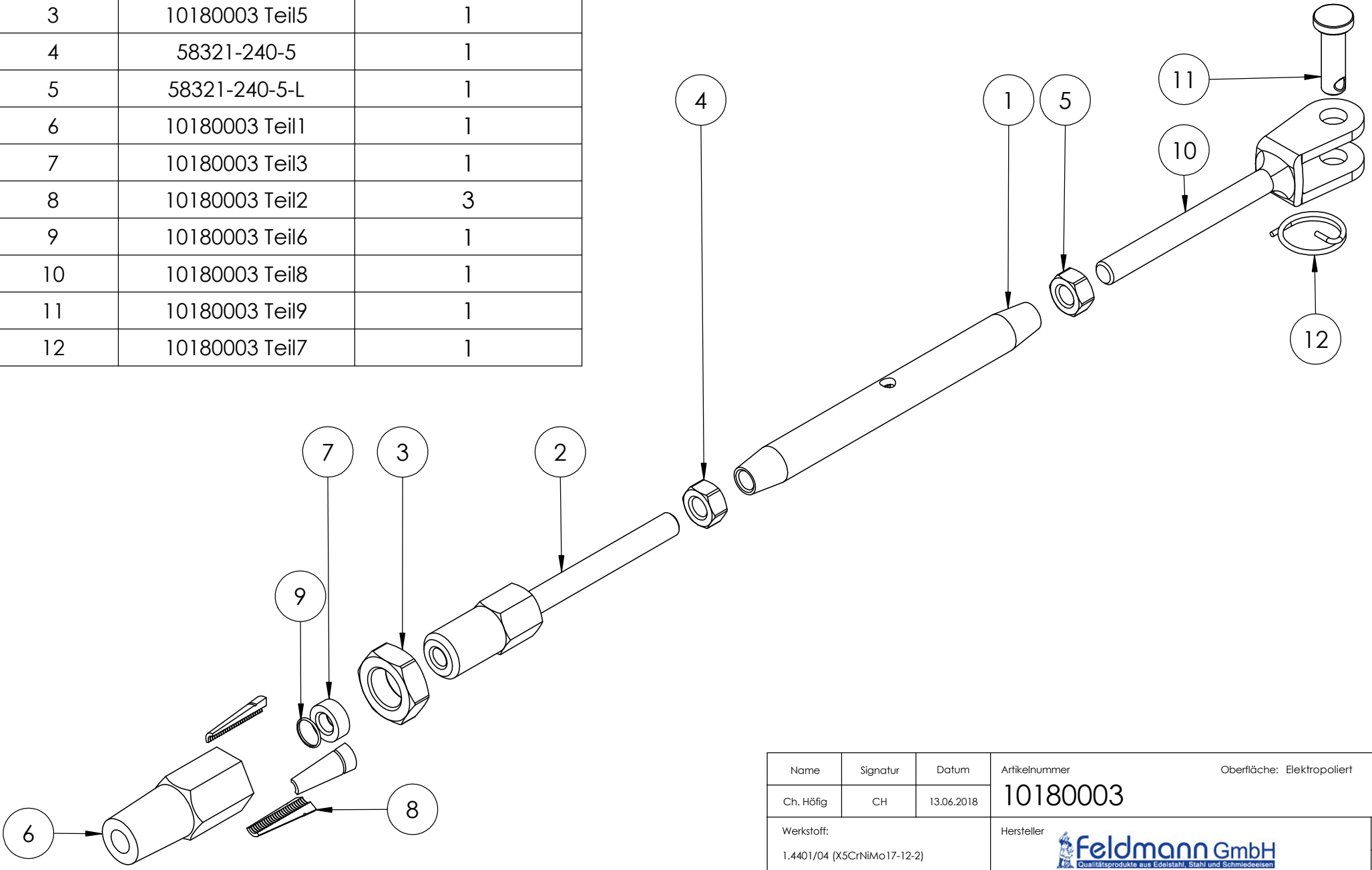

Name	Signatur	Datum	Artikelnummer	Oberfläche: Elektropoliert
Ch. Höfig	CH	13.06.2018	10180003	
Werkstoff: 1.4401/04 (X5CrNiMo17-12-2)			Hersteller  Qualitätsprodukte aus Edelstahl, Stahl und Schmiedeeisen	Blattformat A4
Gewicht 0,085 kg		Massstab: 1:1	Version: 1	Blatt 12 von 12