

Name	Signatur	Datum	Artikelnummer	Oberfläche: Geschliffen Korn 240
Ch. Höfig	CH	31.03.2020	24-V2A-90	
Werkstoff: 1.4301 (X5CrNi18-10)			Hersteller	Blattformat
			 Feldmann EDELSTAHL-ALUMINIUM-SCHMIEDEISEN	A4
Gewicht 0,686 kg		Massstab: 1:2	Version: 1	Blatt 1 von 6

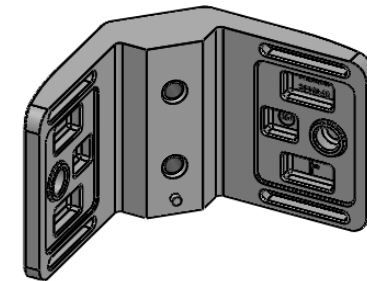

Name	Signatur	Datum	Artikelnummer	Oberfläche: Geschliffen Korn 240
Ch. Höfig	CH	31.03.2020	24-V2A-90 Teil1	
Werkstoff: 1.4301 (X5CrNi18-10)			Hersteller	Blattformat
			 Feldmann EDELSTAHL-ALUMINIUM-SCHMIEDEISEN	A4
Gewicht 0,422 kg		Massstab: 1:2	Version: 1	Blatt 2 von 6

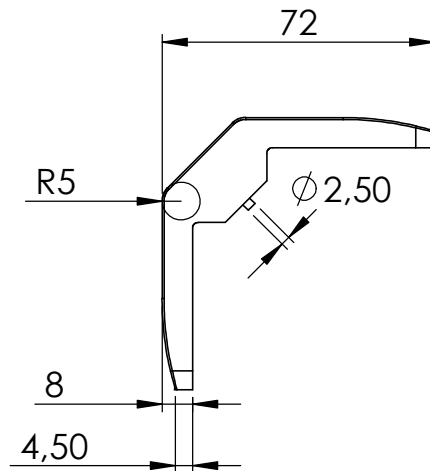
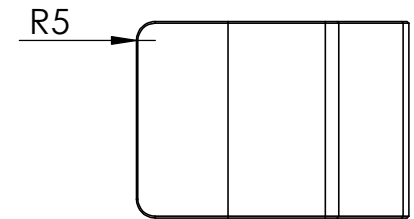
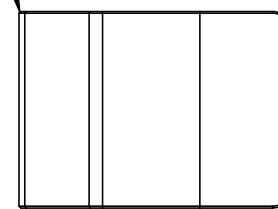
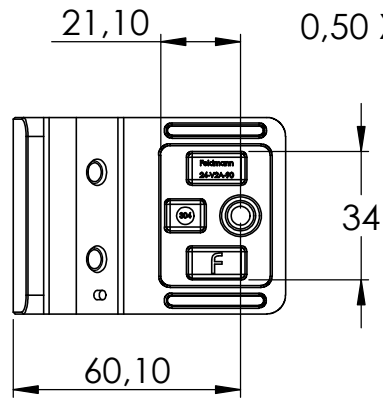
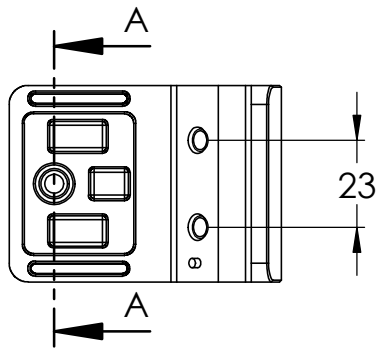
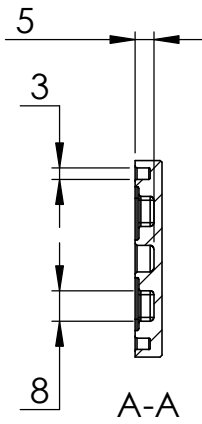
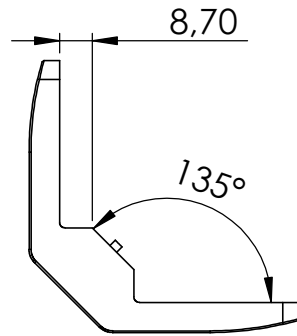
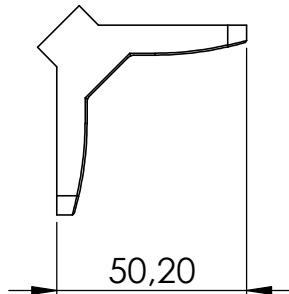
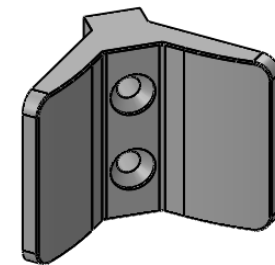
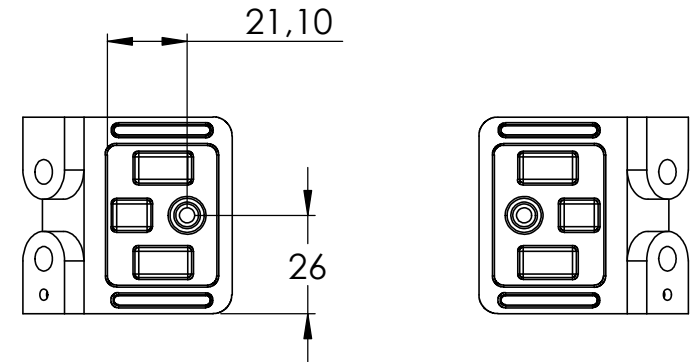
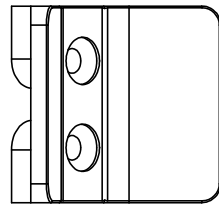
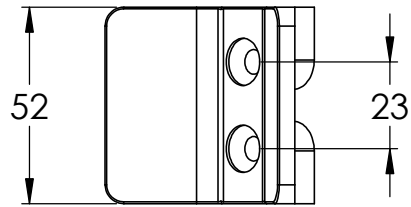
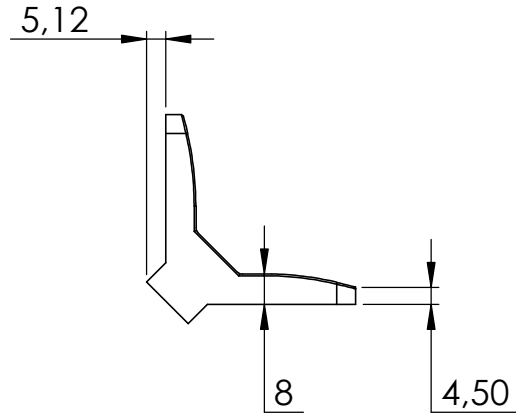

Name	Signatur	Datum	Artikelnummer	Oberfläche: Geschliffen Korn 240	
Ch. Höfig	CH	31.03.2020	24-V2A-90 Teil2		
Werkstoff: 1.4301 (X5CrNi18-10)			Hersteller  Feldmann EDELSTAHL · ALUMINIUM · SCHMIEDEISEN		Blattformat A4
Gewicht 0,254 kg			Massstab: 1:2	Version: 1	Blatt 3 von 6

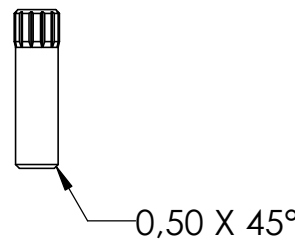
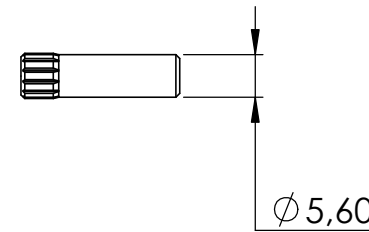
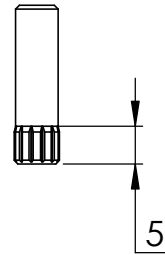
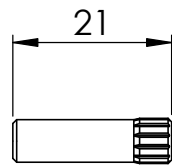

Name	Signatur	Datum	Artikelnummer	Oberfläche: Roh
Ch. Höfig	CH	31.03.2020	24-Stift	
Werkstoff: 1.4401/04 (X5CrNiMo17-12-2)			Hersteller	Blattformat
			 Feldmann EDELSTAHL · ALUMINIUM · SCHMIEDEEISEN	A4
Gewicht 0,004 kg		Massstab: 1:1	Version: 1	Blatt 4 von 6

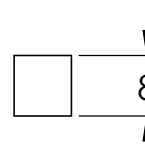
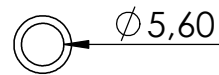
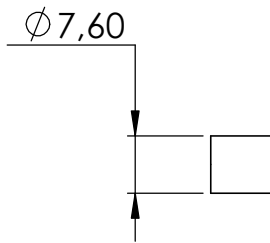

Name	Signatur	Datum	Artikelnummer	Oberfläche: Roh
Ch. Höfig	CH	31.03.2020	24-Stift	
Werkstoff: EPDM			Hersteller	Blattformat
			 Feldmann EDELSTAHL · ALUMINIUM · SCHMIEDEEISEN	A4
Gewicht 0,000 kg		Massstab: 1:1	Version: 1	Blatt 5 von 6

POS-NR.	BENENNUNG	MENGE
1	24-V2A-90 Teil1	1
2	24-V2A-90 Teil2	1
3	DIN 7991 - M6 x 25 --- 25S	2
4	24-Kappe	2
5	24-Stift	2
6	24-Stift	2

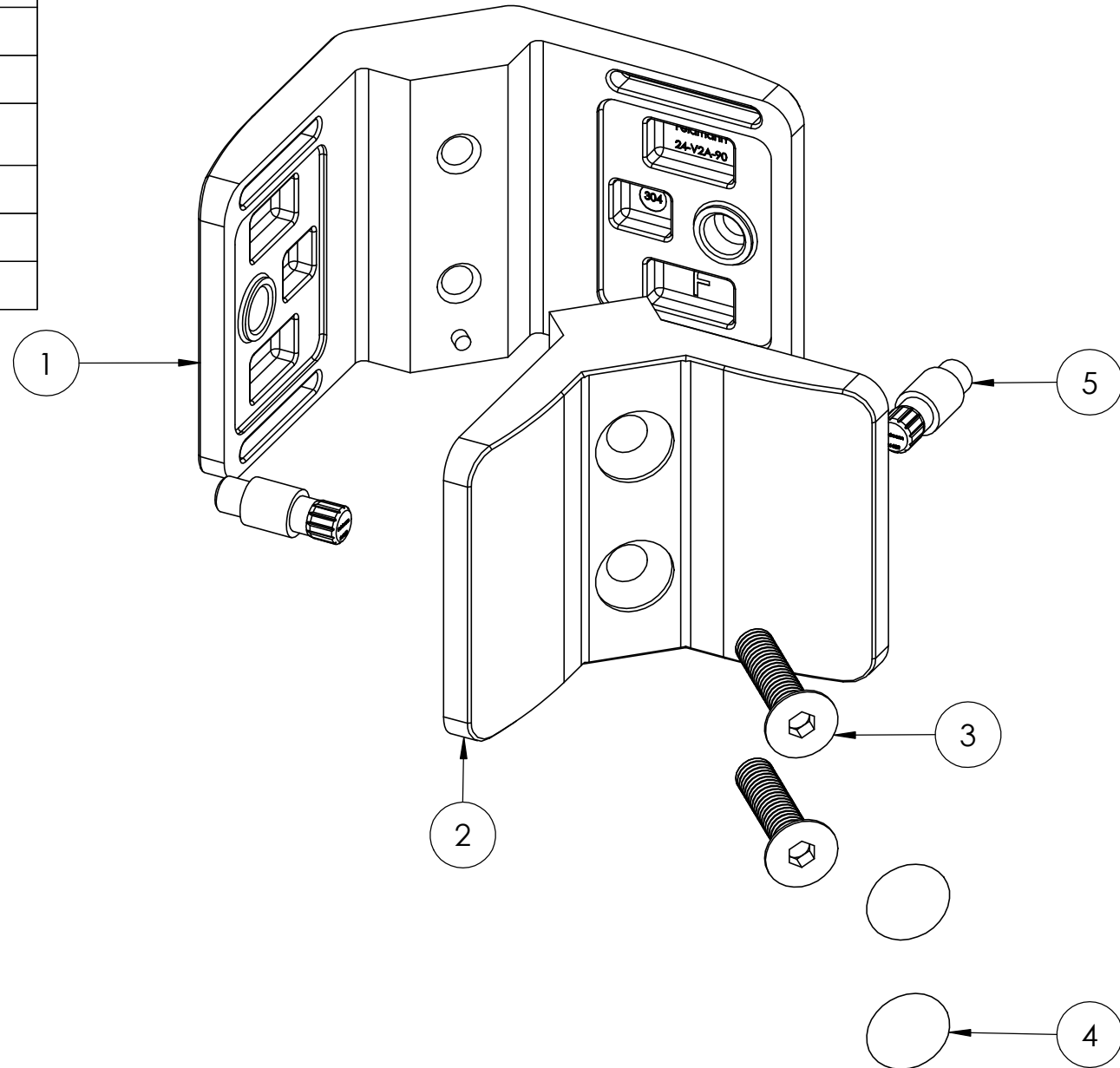

Name	Signatur	Datum	Artikelnummer	Oberfläche: Geschliffen Korn 240
Ch. Höfig	CH	31.03.2020	24-V2A-90	
Werkstoff: 1.4301 (X5CrNi18-10)			Hersteller	Blattformat
			 Feldmann EDELSTAHL-ALUMINIUM-SCHMIEDEISEN	A4
Gewicht 0,686 kg			Massstab: 1:1	Version: 1
			Blatt 6 von 6	