

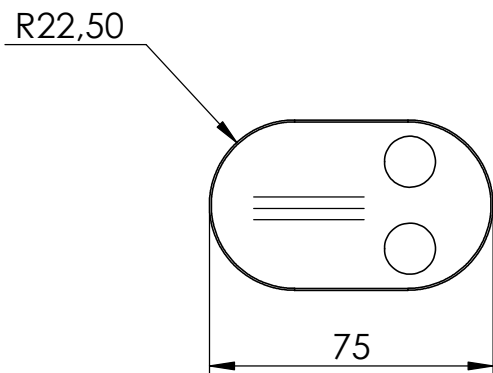

Sicherungsstift und  
Sicherungsboden  
optional erhältlich

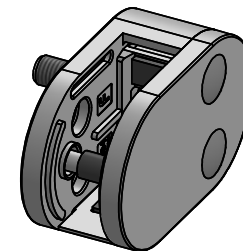

DIN 912  
M8x25

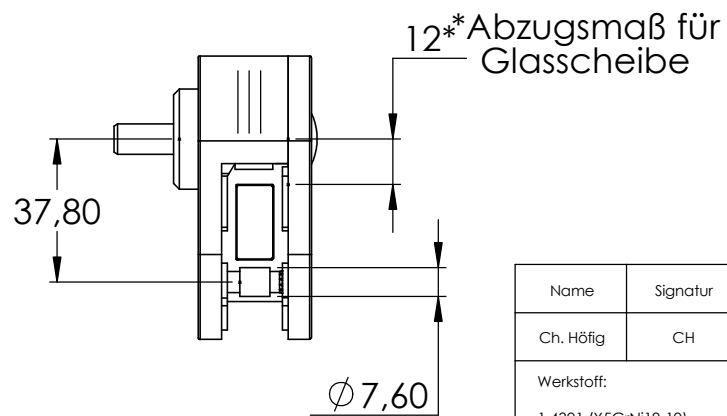
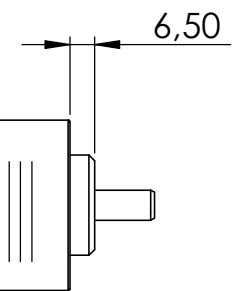
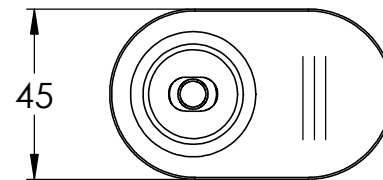
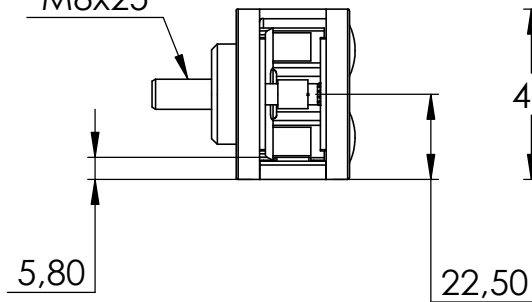

|                                    |          |               |                                                                                                                                               |                                  |
|------------------------------------|----------|---------------|-----------------------------------------------------------------------------------------------------------------------------------------------|----------------------------------|
| Name                               | Signatur | Datum         | Artikelnummer                                                                                                                                 | Oberfläche: Geschliffen Korn 240 |
| Ch. Höfig                          | CH       | 17.03.2021    | 25-EK-V2A                                                                                                                                     |                                  |
| Werkstoff:<br>1.4301 (X5CrNi18-10) |          |               | Hersteller                                                                                                                                    | Blattformat                      |
|                                    |          |               |  <b>Feldmann</b><br>EDELSTAHL · ALUMINIUM · SCHMIEDEISEN | A4                               |
| Gewicht 0,388 kg                   |          | Massstab: 1:2 | Version: 1                                                                                                                                    | Blatt 1 von 8                    |

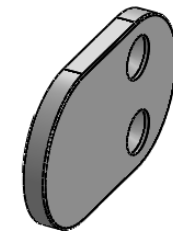
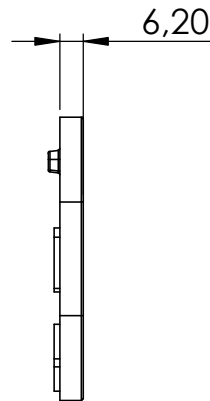
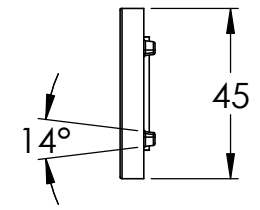
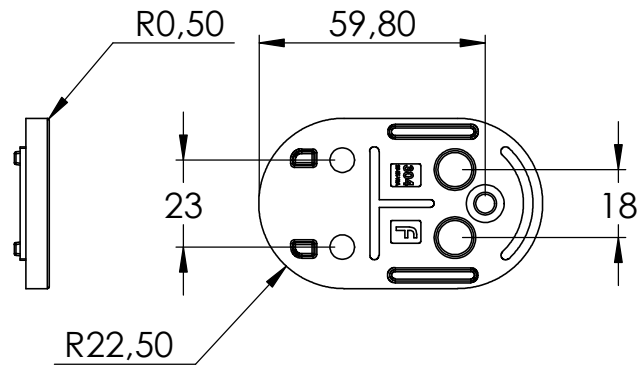
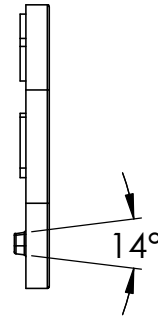
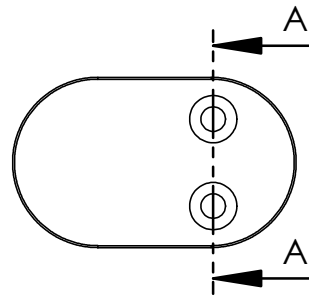
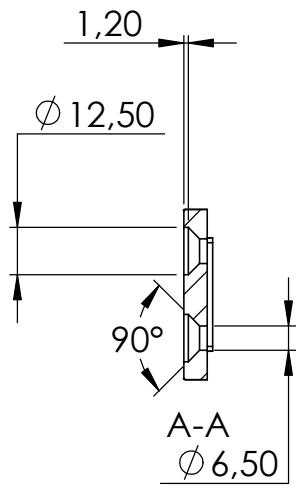

|                                           |          |               |                                                                                                                                           |                                  |
|-------------------------------------------|----------|---------------|-------------------------------------------------------------------------------------------------------------------------------------------|----------------------------------|
| Name                                      | Signatur | Datum         | Artikelnummer                                                                                                                             | Oberfläche: Geschliffen Korn 240 |
| Ch. Höfig                                 | CH       | 17.03.2021    | 25-EK-V2A Teil1                                                                                                                           |                                  |
| Werkstoff:<br>1.4401/04 (X5CrNiMo17-12-2) |          |               | Hersteller                                                                                                                                | Blattformat                      |
|                                           |          |               |  <b>Feldmann</b><br>EDELSTAHL-ALUMINIUM-SCHMIEDEISEN | A4                               |
| Gewicht 0,132 kg                          |          | Massstab: 1:2 | Version: 1                                                                                                                                | Blatt 2 von 8                    |

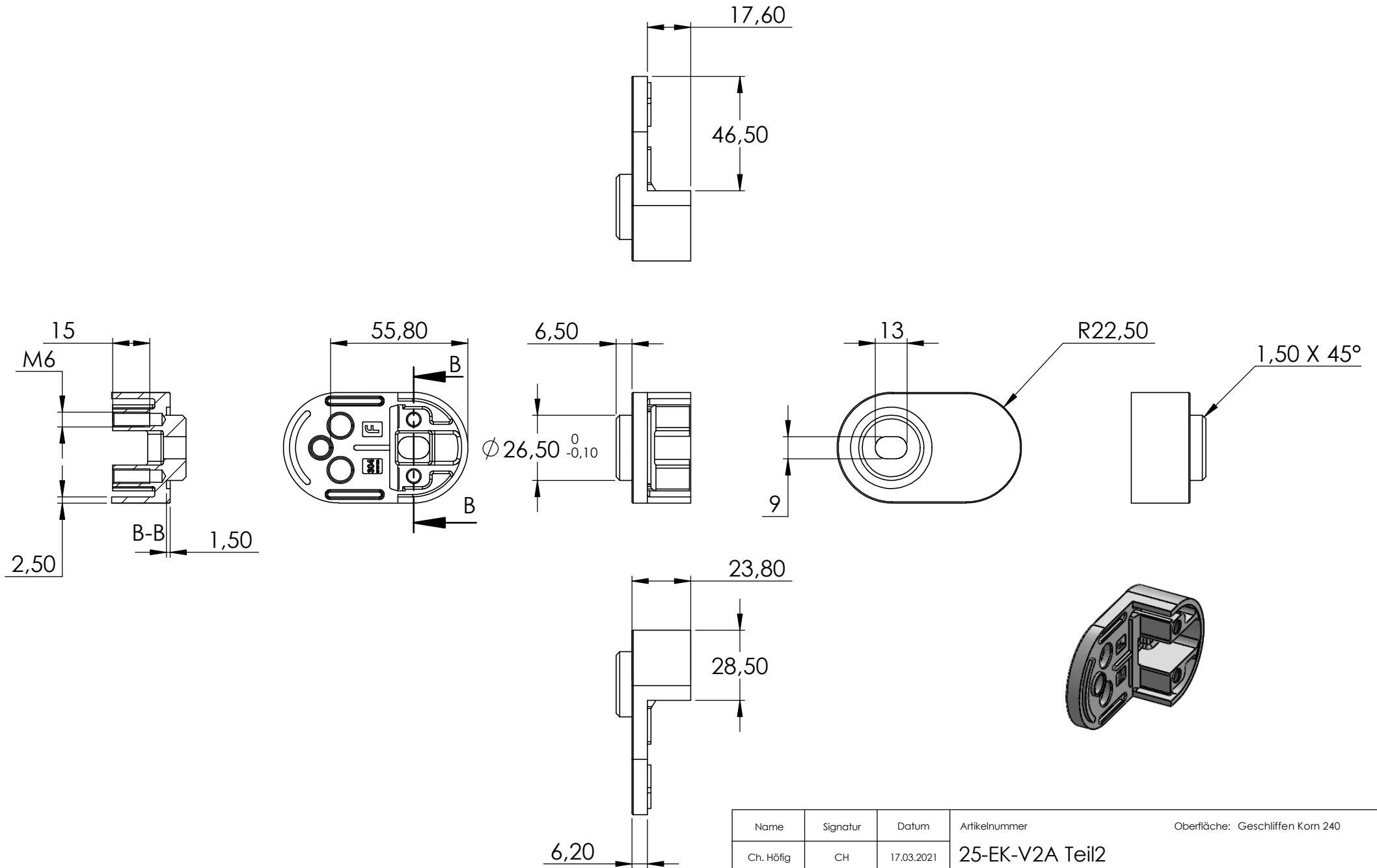

|                                    |          |               |                                                                                                                                               |                                  |
|------------------------------------|----------|---------------|-----------------------------------------------------------------------------------------------------------------------------------------------|----------------------------------|
| Name                               | Signatur | Datum         | Artikelnummer                                                                                                                                 | Oberfläche: Geschliffen Korn 240 |
| Ch. Höfig                          | CH       | 17.03.2021    | 25-EK-V2A Teil2                                                                                                                               |                                  |
| Werkstoff:<br>1.4301 (X5CrNi18-10) |          |               | Hersteller                                                                                                                                    | Blattformat                      |
|                                    |          |               |  <b>Feldmann</b><br>EDELSTAHL · ALUMINIUM · SCHMIEDEISEN | A4                               |
| Gewicht 0,209 kg                   |          | Massstab: 1:2 | Version: 1                                                                                                                                    | Blatt 3 von 8                    |

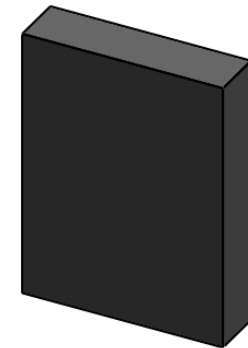
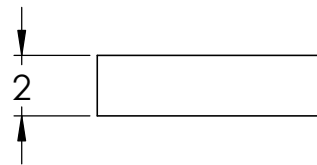
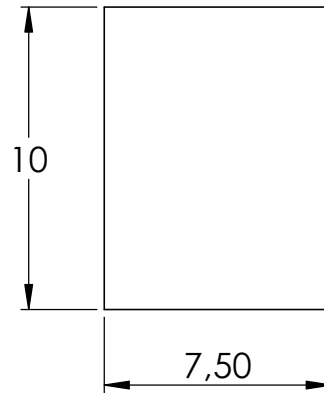

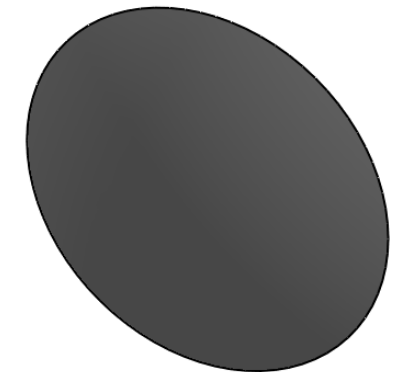
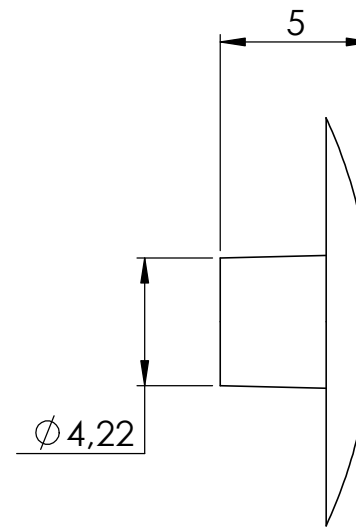
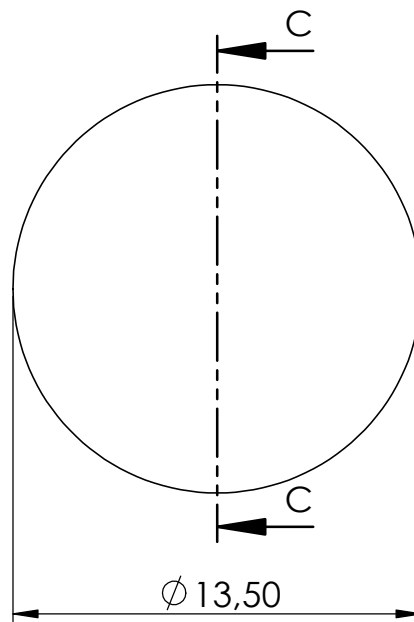
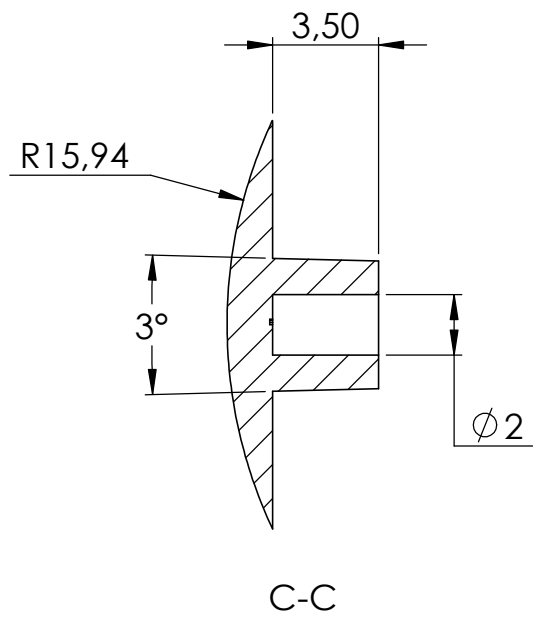

|                    |          |            |                                                                                       |                 |
|--------------------|----------|------------|---------------------------------------------------------------------------------------|-----------------|
| Name               | Signatur | Datum      | Artikelnummer                                                                         | Oberfläche: Roh |
| Ch. Höfig          | CH       | 17.03.2021 | 25-EK-XXX Teil3                                                                       |                 |
| Werkstoff:<br>EPDM |          |            | Hersteller                                                                            | Blattformat     |
|                    |          |            |  |                 |
| Gewicht 0,000 kg   |          |            | Massstab: 4:1                                                                         | Version: 1      |
|                    |          |            | Blatt 4 von 8                                                                         |                 |
|                    |          |            | A4                                                                                    |                 |

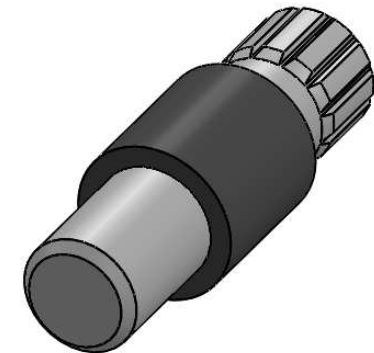
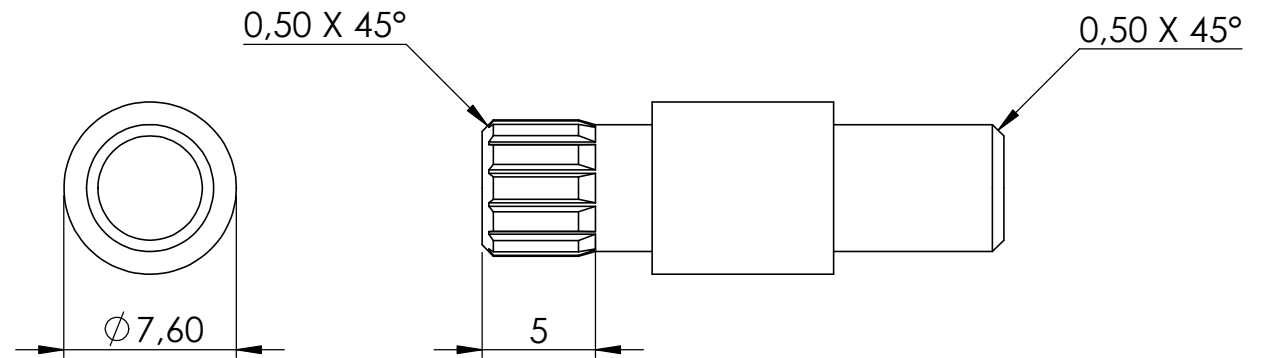
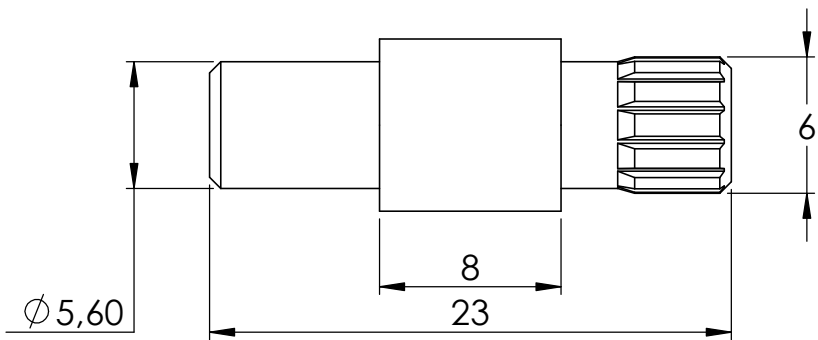

|                           |          |            |                                                                                                                                               |                 |
|---------------------------|----------|------------|-----------------------------------------------------------------------------------------------------------------------------------------------|-----------------|
| Name                      | Signatur | Datum      | Artikelnummer                                                                                                                                 | Oberfläche: Roh |
| Ch. Höfig                 | CH       | 17.03.2021 | GK-P-G                                                                                                                                        |                 |
| Werkstoff:<br>Polyethylen |          |            | Hersteller                                                                                                                                    | Blattformat     |
|                           |          |            |  <b>Feldmann</b><br>EDELSTAHL · ALUMINIUM · SCHMIEDEISEN | A4              |
| Gewicht 0,000 kg          |          |            | Massstab: 4:1    Version: 1                                                                                                                   | Blatt 5 von 8   |

Sicherungstift optional erhältlich



|                                           |          |               |                                                                                                                                                |                 |
|-------------------------------------------|----------|---------------|------------------------------------------------------------------------------------------------------------------------------------------------|-----------------|
| Name                                      | Signatur | Datum         | Artikelnummer                                                                                                                                  | Oberfläche: Roh |
| Ch. Höfig                                 | CH       | 17.03.2021    | 25-STIFT                                                                                                                                       |                 |
| Werkstoff:<br>1.4401/04 (X5CrNiMo17-12-2) |          |               | Hersteller                                                                                                                                     | Blattformat     |
|                                           |          |               |  <b>Feldmann</b><br>EDELSTAHL · ALUMINIUM · SCHMIEDEEISEN | A4              |
| Gewicht 0,005 kg                          |          | Massstab: 3:1 | Version: 1                                                                                                                                     | Blatt 6 von 8   |

Sicherungsboden optional erhältlich

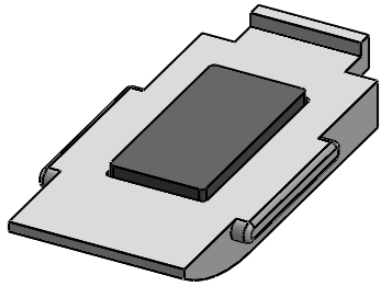
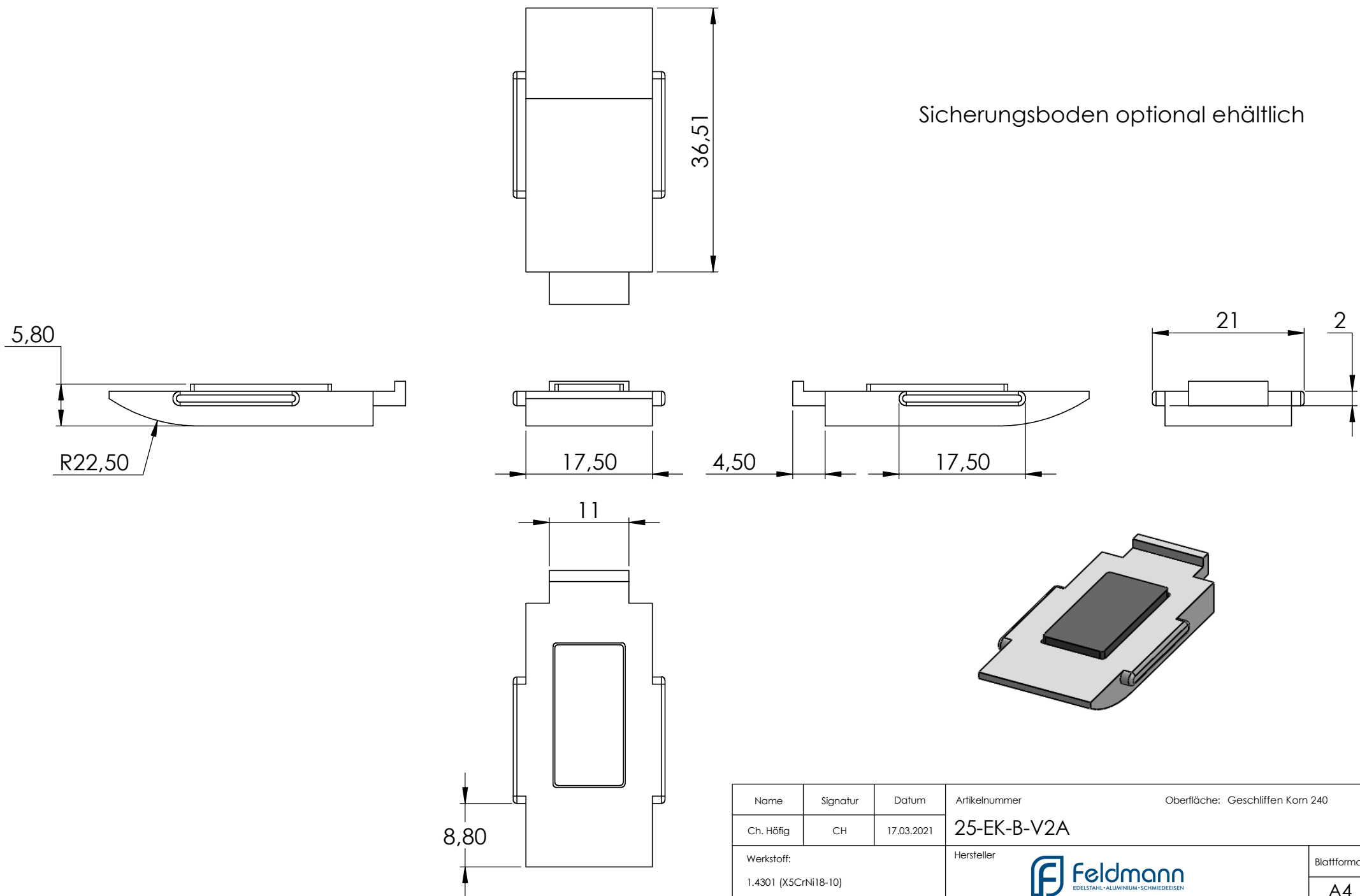

|                                    |          |            |                                                                                                                                                |                                  |
|------------------------------------|----------|------------|------------------------------------------------------------------------------------------------------------------------------------------------|----------------------------------|
| Name                               | Signatur | Datum      | Artikelnummer                                                                                                                                  | Oberfläche: Geschliffen Korn 240 |
| Ch. Höfig                          | CH       | 17.03.2021 | 25-EK-B-V2A                                                                                                                                    |                                  |
| Werkstoff:<br>1.4301 (X5CrNi18-10) |          |            | Hersteller                                                                                                                                     | Blattformat                      |
|                                    |          |            |  <b>Feldmann</b><br>EDELSTAHL · ALUMINIUM · SCHMIEDEEISEN | A4                               |
| Gewicht 0,023 kg                   |          |            | Massstab: 1,5:1    Version: 1                                                                                                                  | Blatt 7 von 8                    |

| POS-NR. | BENENNUNG                     | MENGE |
|---------|-------------------------------|-------|
| 1       | 25-EK-V2A Teil2               | 1     |
| 2       | 25-EK-V2A Teil1               | 1     |
| 3       | 25-EK-XXX Teil3               | 2     |
| 4       | M8x25                         | 1     |
| 5       | GK-P-G                        | 2     |
| 6       | DIN 7991 - M6 x 16 ---<br>16S | 2     |
| 7       | 25-EK-B-V2A                   | 1     |
| 8       | 25-STIFT                      | 1     |

\*Sicherungsstift und  
Sicherungsboden  
optional erhältlich

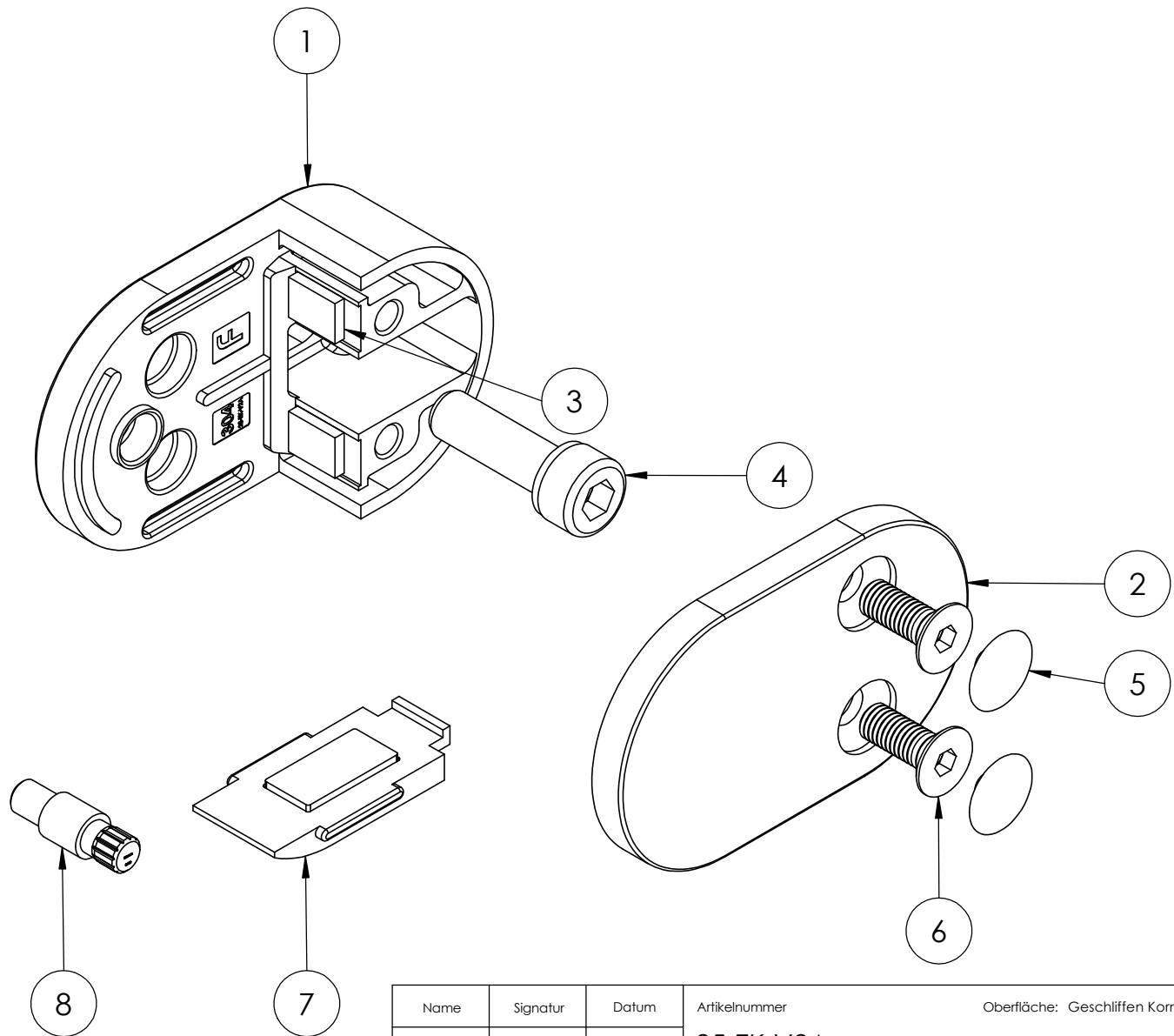

|                                    |          |               |                                                                                                                                           |                                  |
|------------------------------------|----------|---------------|-------------------------------------------------------------------------------------------------------------------------------------------|----------------------------------|
| Name                               | Signatur | Datum         | Artikelnummer                                                                                                                             | Oberfläche: Geschliffen Korn 240 |
| Ch. Höfig                          | CH       | 17.03.2021    | 25-EK-V2A                                                                                                                                 |                                  |
| Werkstoff:<br>1.4301 (X5CrNi18-10) |          |               | Hersteller                                                                                                                                | Blattformat                      |
|                                    |          |               |  <b>Feldmann</b><br>EDELSTAHL-ALUMINIUM-SCHMIEDEISEN | A4                               |
| Gewicht 0,388 kg                   |          | Massstab: 1:1 | Version: 1                                                                                                                                | Blatt 8 von 8                    |