

SCHNITT A-A

Name	Signatur	Datum	Artikelnummer	Oberfläche: Geschliffen Korn 240
Ch. Höfig	CH	02.09.2019	40500-240	
Werkstoff: 1.4301 (X5CrNi18-10)			Hersteller	Blattformat
			 Feldmann EDELSTAHL-ALUMINIUM-SCHMIEDEISEN	A4
Gewicht 2,795 kg		Massstab: 1:15	Version: 1	Blatt 1 von 5

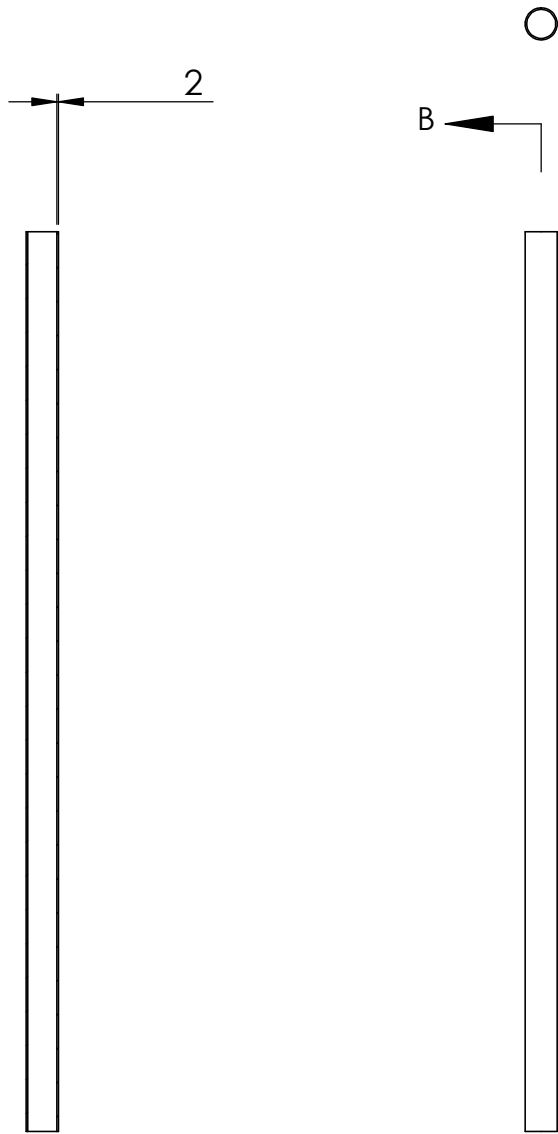

SCHNITT B-B

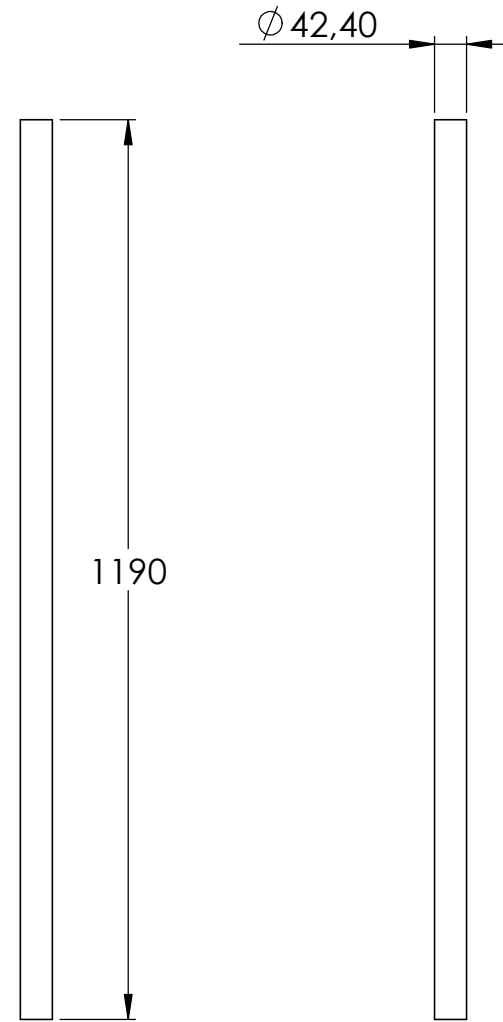
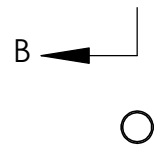

Name	Signatur	Datum	Artikelnummer	Oberfläche: Geschliffen Korn 240
Ch. Höfig	CH	02.09.2019	40500-240 Teil1	
Werkstoff: 1.4301 (X5CrNi18-10)			Hersteller	Blattformat
			 Feldmann EDELSTAHL-ALUMINIUM-SCHMIEDEISEN	A4
Gewicht 2,386 kg		Massstab: 1:10	Version: 1	Blatt 2 von 5

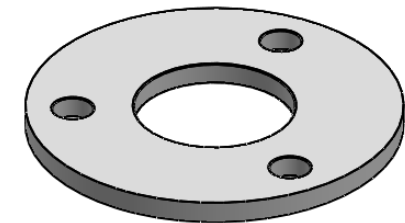
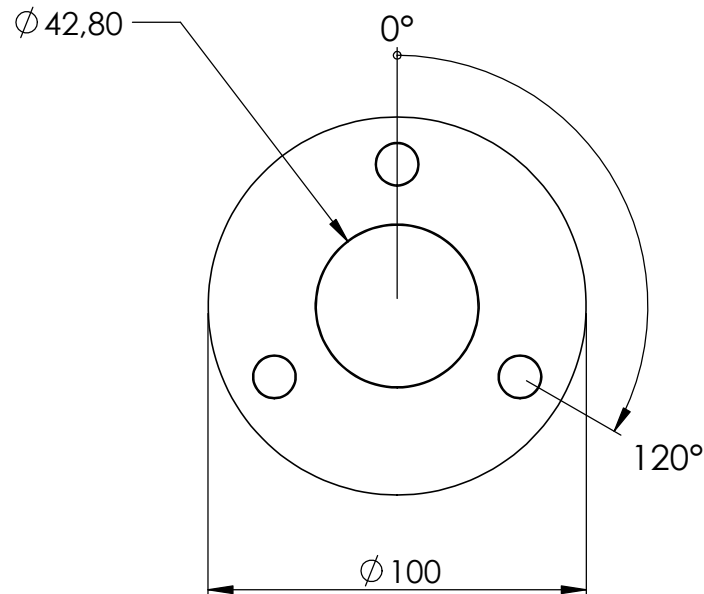
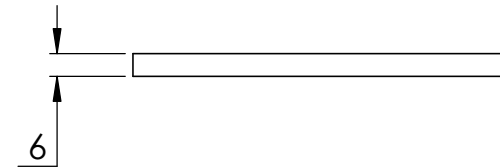
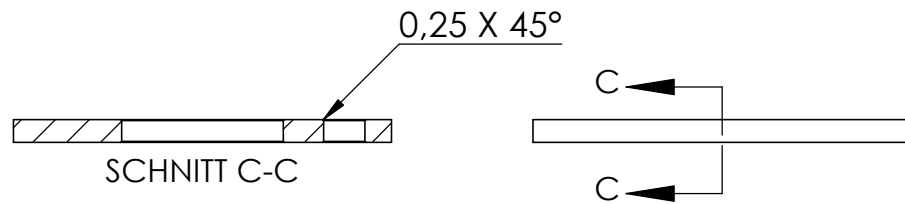
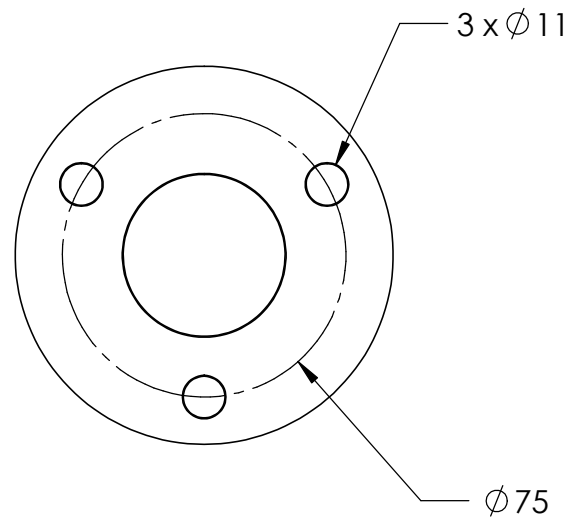

Name	Signatur	Datum	Artikelnummer	Oberfläche: Längsschliff Korn 240
Ch. Höfig	CH	02.09.2019	54106-240	
Werkstoff: 1.4301 (X5CrNi18-10)			Hersteller	Blattformat
			 Feldmann EDELSTAHL · ALUMINIUM · SCHMIEDEISEN	A4
Gewicht 0,290 kg		Massstab: 1:2	Version: 1	Blatt 3 von 5

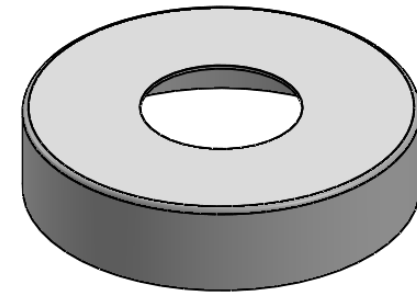
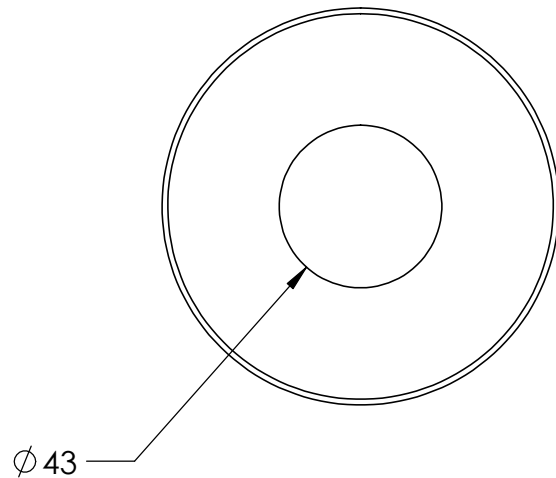
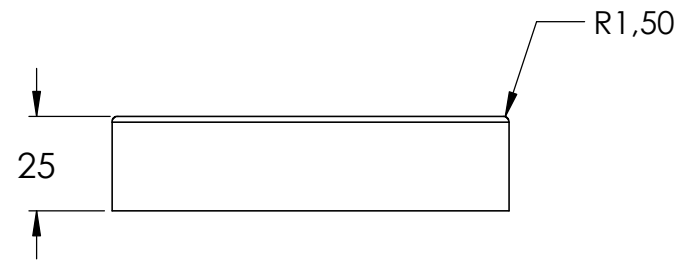
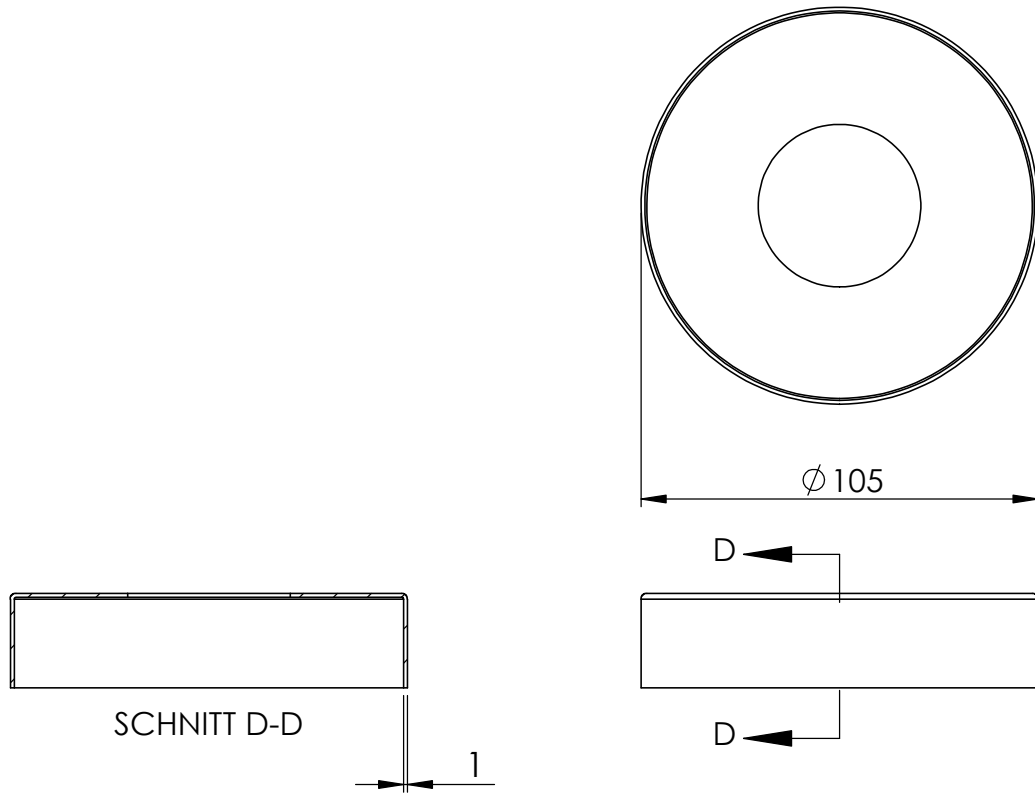

Name	Signatur	Datum	Artikelnummer	Oberfläche: Rundschliff Korn 240
Ch. Höfig	CH	02.09.2019	50152-240	
Werkstoff: 1.4301 (X5CrNi18-10)			Hersteller	Blattformat
			 Feldmann EDELSTAHL · ALUMINIUM · SCHMIEDEEISEN	A4
Gewicht 0,118 kg		Massstab: 1:2	Version: 1	Blatt 4 von 5

POS-NR.	BENENNUNG	MENGE
1	40500-240 Teil1	1
2	54106-240	1
3	50152-240	1

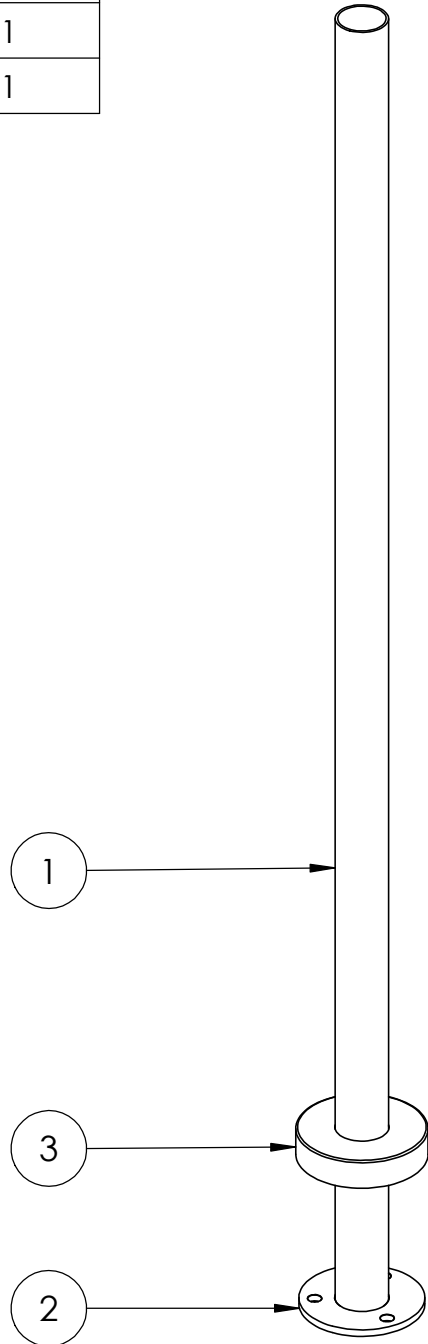

Name	Signatur	Datum	Artikelnummer	Oberfläche: Geschliffen Korn 240
Ch. Höfig	CH	02.09.2019	40500-240	
Werkstoff: 1.4301 (X5CrNi18-10)			Hersteller	Blattformat
			 Feldmann EDELSTAHL · ALUMINIUM · SCHMIEDEEISEN	A4
Gewicht 2,795 kg		Massstab: 1:6	Version: 1	Blatt 5 von 5