

SCHNITT A-A

0°

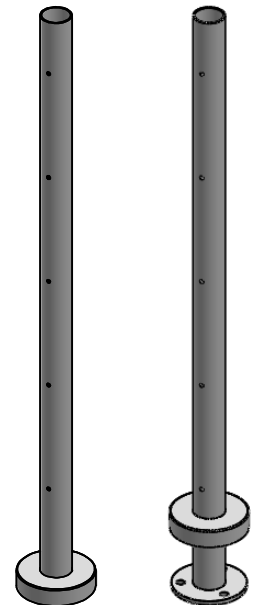

Name	Signatur	Datum	Artikelnummer	Oberfläche: Geschliffen Korn 240	
Ch. Höfig	CH	02.09.2019	40511-240		
Werkstoff: 1.4301 (X5CrNi18-10)			Hersteller	 <b>Feldmann</b> <small>EDELSTAHL · ALUMINIUM · SCHMIEDEISEN</small>	Blattformat
Gewicht 2,171 kg			Massstab: 1:10		Version: 1
			Blatt 1 von 5		

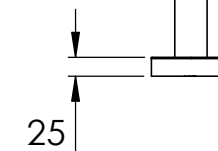
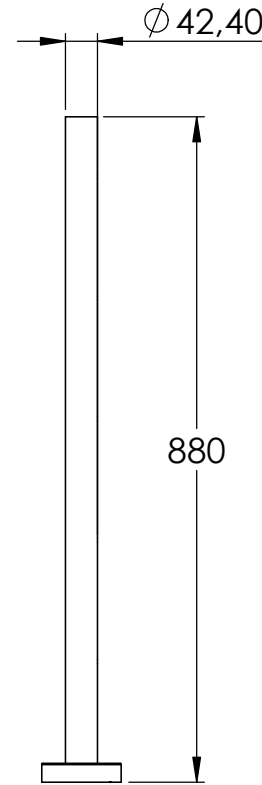
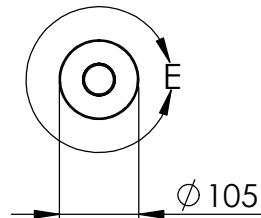
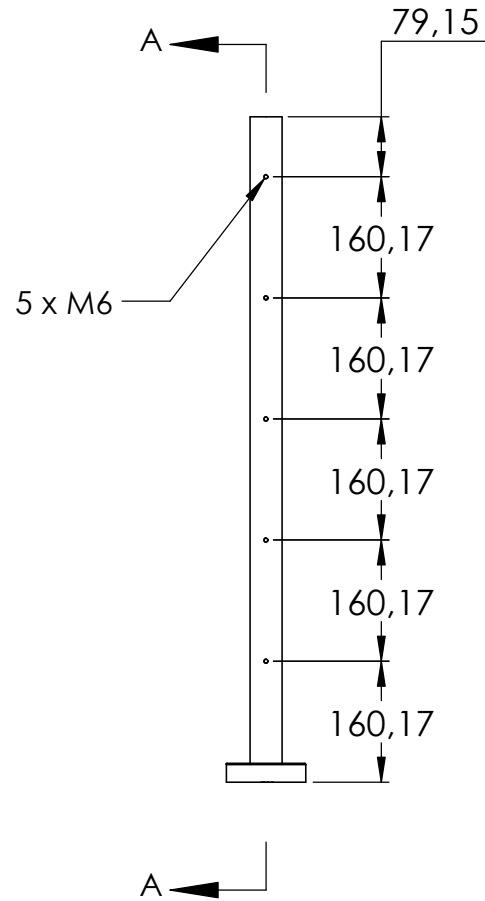
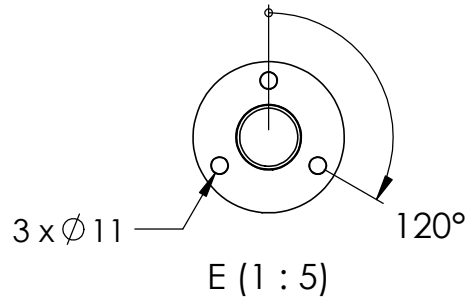
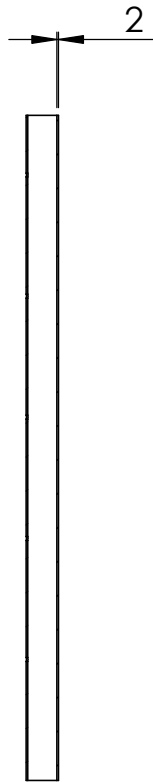

SCHNITT B-B

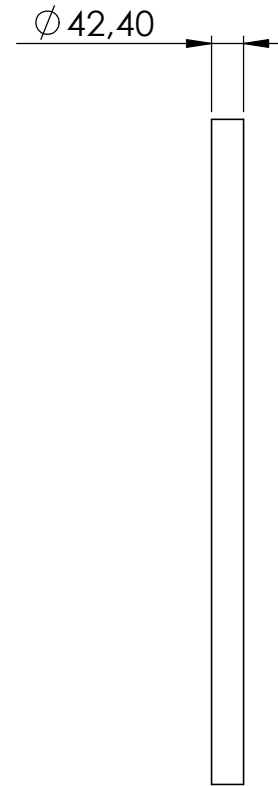
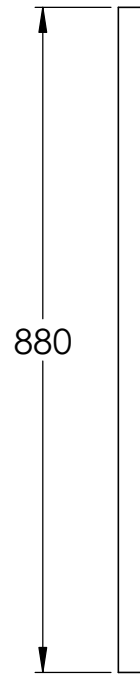
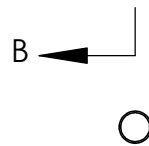
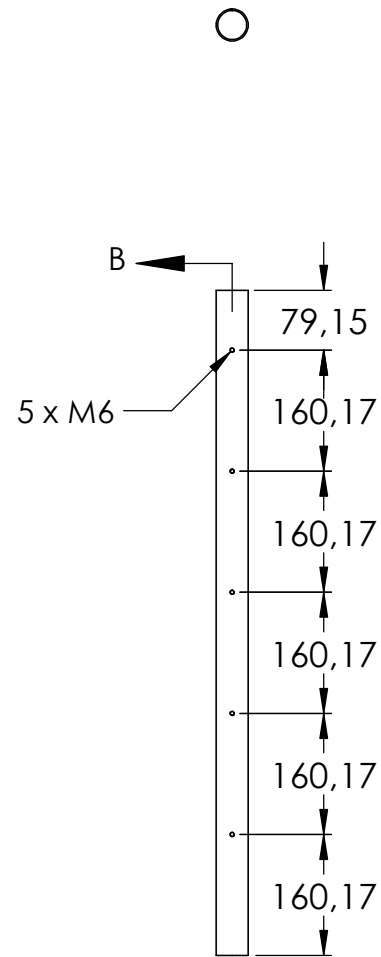

Name	Signatur	Datum	Artikelnummer	Oberfläche: Geschliffen Korn 240
Ch. Höfig	CH	02.09.2019	40511-240 Teil 1	
Werkstoff: 1.4301 (X5CrNi18-10)			Hersteller	Blattformat
			 <b>Feldmann</b> EDELSTAHL · ALUMINIUM · SCHMIEDEEISEN	A4
Gewicht 1.763 kg		Massstab: 1:10	Version: 1	Blatt 2 von 5

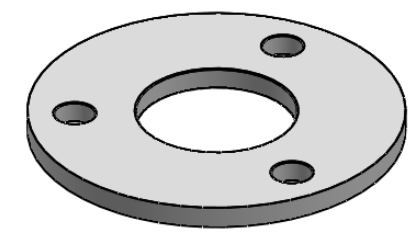
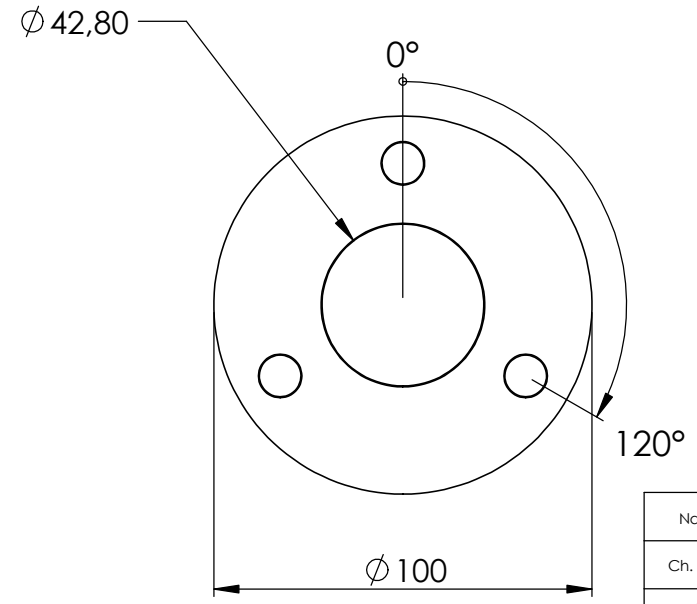
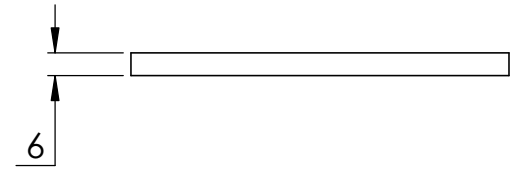
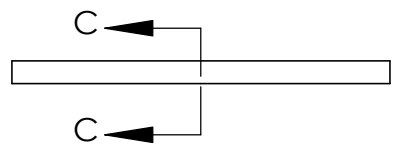
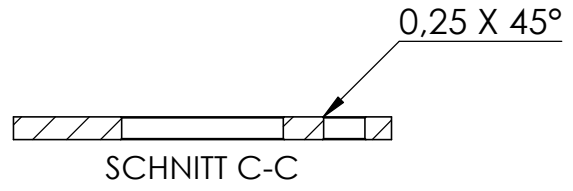
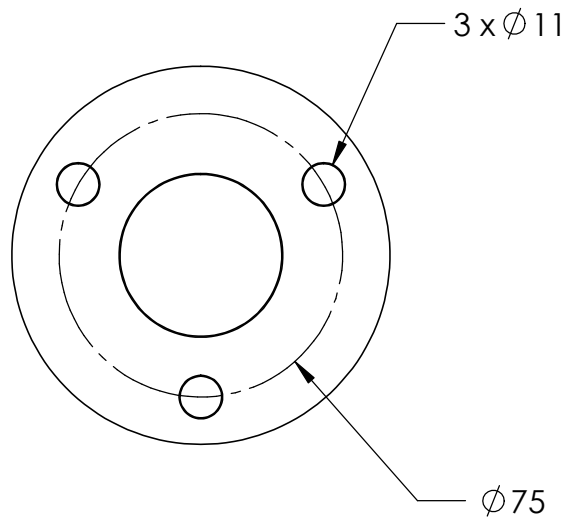

Name	Signatur	Datum	Artikelnummer	Oberfläche: Längsschliff Korn 240
Ch. Höfig	CH	02.09.2019	54106-240	
Werkstoff: 1.4301 (X5CrNi18-10)			Hersteller	Blattformat
			 <b>Feldmann</b> EDELSTAHL · ALUMINIUM · SCHMIEDEEISEN	A4
Gewicht 0,290 kg		Massstab: 1:2	Version: 1	Blatt 3 von 5

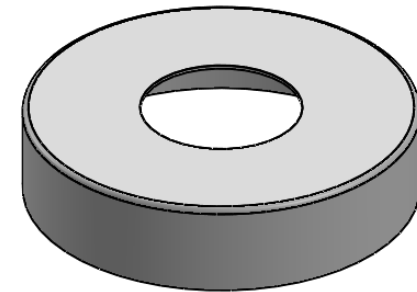
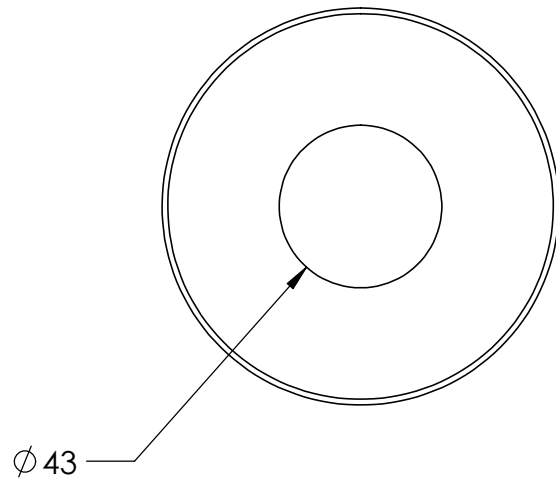
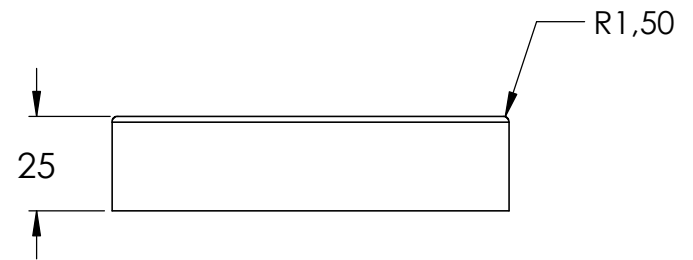
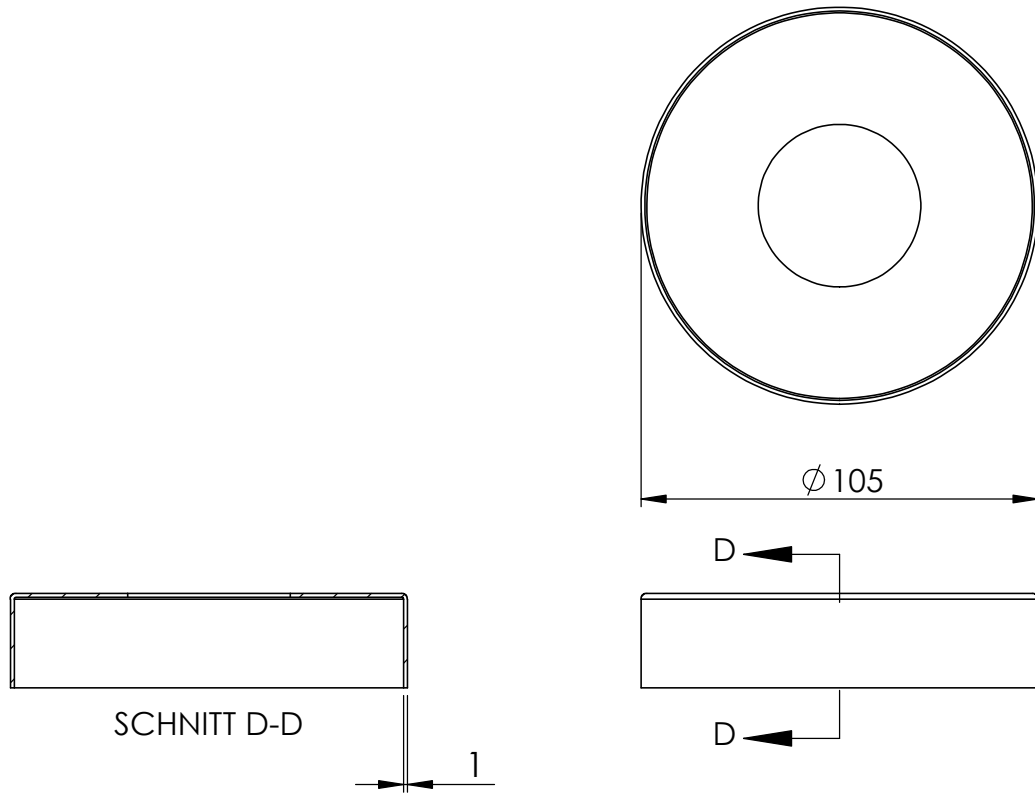

Name	Signatur	Datum	Artikelnummer	Oberfläche: Rundschliff Korn 240
Ch. Höfig	CH	02.09.2019	50152-240	
Werkstoff: 1.4301 (X5CrNi18-10)			Hersteller	Blattformat
			 <b>Feldmann</b> EDELSTAHL · ALUMINIUM · SCHMIEDEISEN	A4
Gewicht 0,118 kg		Massstab: 1:2	Version: 1	Blatt 4 von 5

POS-NR.	BENENNUNG	MENGE
1	40511-240 Teil1	1
2	54106-240	1
3	50152-240	1

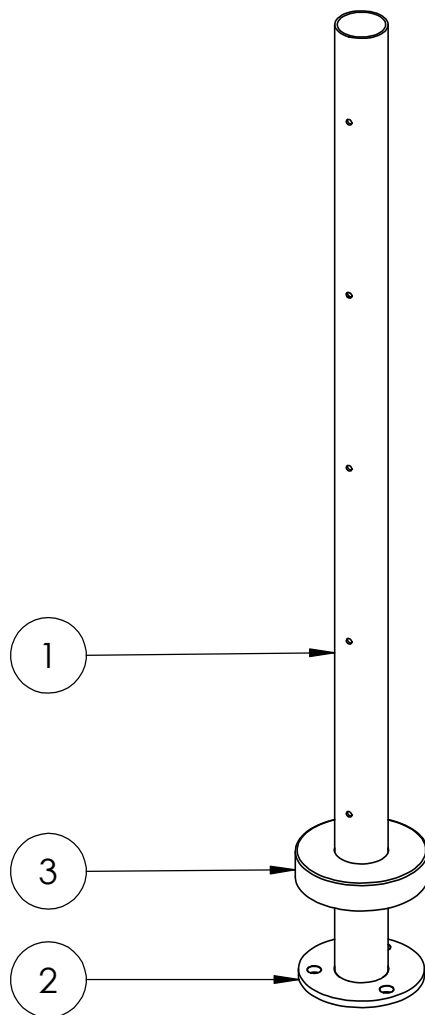

Name	Signatur	Datum	Artikelnummer	Oberfläche: Geschliffen Korn 240
Ch. Höfig	CH	02.09.2019	40511-240	
Werkstoff: 1.4301 (X5CrNi18-10)			Hersteller	Blattformat
			 <b>Feldmann</b> EDELSTAHL · ALUMINIUM · SCHMIEDEEISEN	A4
Gewicht 2,171 kg		Massstab: 1:6	Version: 1	Blatt 5 von 5