

Name	Signatur	Datum	Artikelnummer	Oberfläche: Geschliffen Korn 240	
Ch. Höfig	CH	02.09.2019	40541-240		
Werkstoff:			Hersteller		Blattformat
1.4301 (X5CrNi18-10)			 Feldmann <small>EDELSTAHL-ALUMINIUM-SCHMIEDEISEN</small>		A4
Gewicht 3,649 kg			Massstab: 1:10	Version: 1	Blatt 1 von 6

4 x M8 Gewinde (180° versetzt)

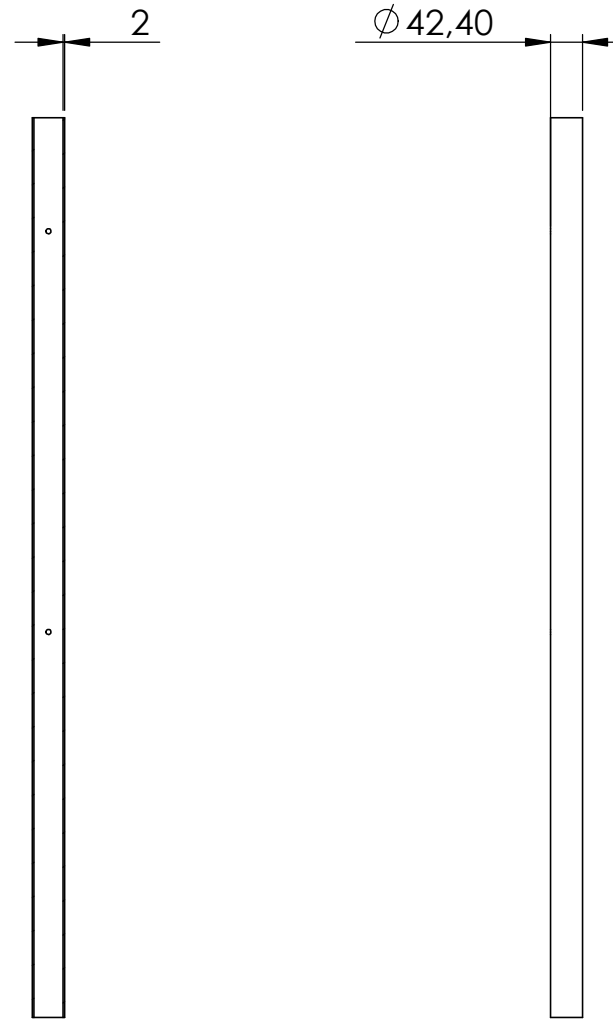

SCHNITT B-B

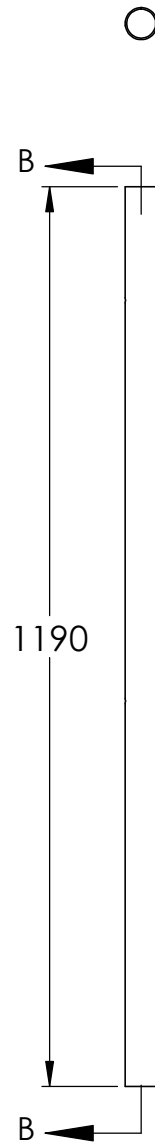
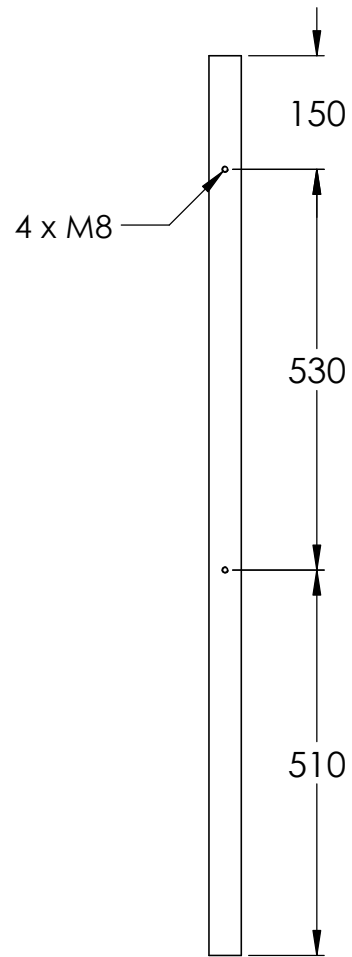

Name	Signatur	Datum	Artikelnummer	Oberfläche: Geschliffen Korn 240
Ch. Höfig	CH	02.09.2019	40541-240 Teil1	
Werkstoff: 1.4301 (X5CrNi18-10)			Hersteller	Blattformat
			 Feldmann EDELSTAHL · ALUMINIUM · SCHMIEDEISEN	A4
Gewicht 2,384 kg		Massstab: 1:10	Version: 1	Blatt 2 von 6

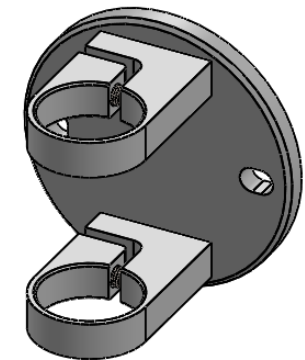
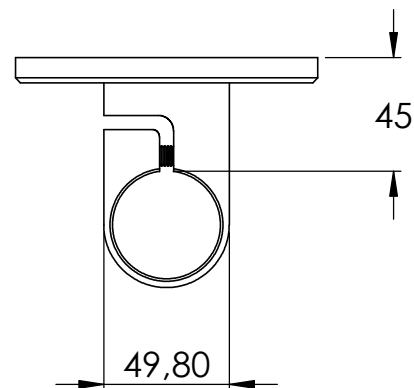
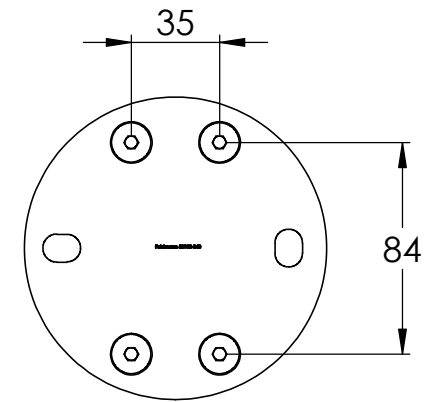
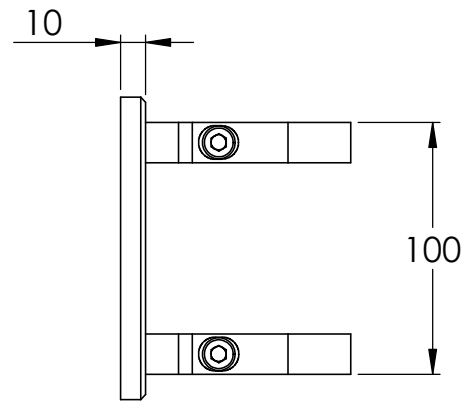
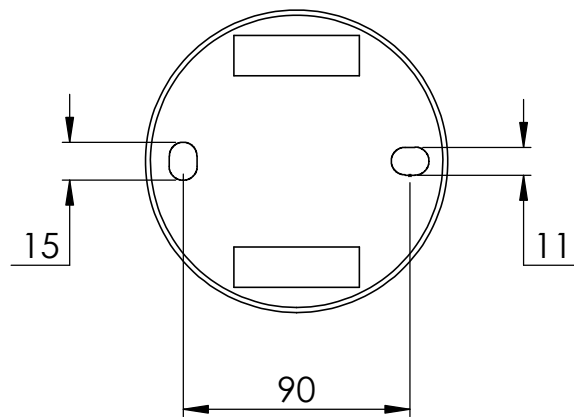
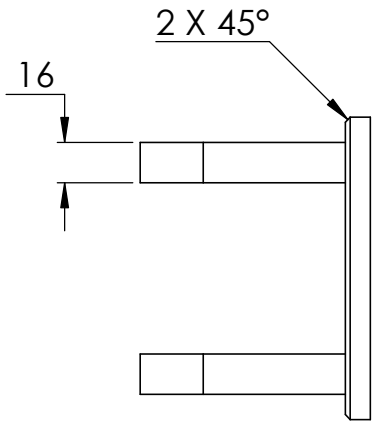
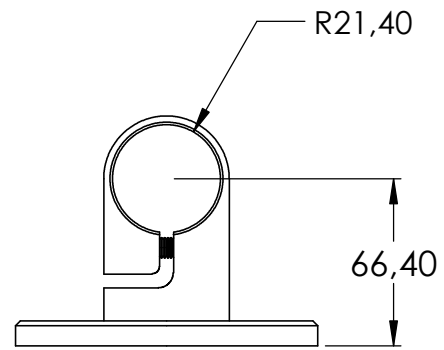

Name	Signatur	Datum	Artikelnummer	Oberfläche: Geschliffen Korn 240	
Ch. Höfig	CH	02.09.2019	50138-240		
Werkstoff: 1.4301 (X5CrNi18-10)			Hersteller		Blattformat
					A4
Gewicht 1.265 kg			Massstab: 1:3	Version: 1	Blatt 3 von 6

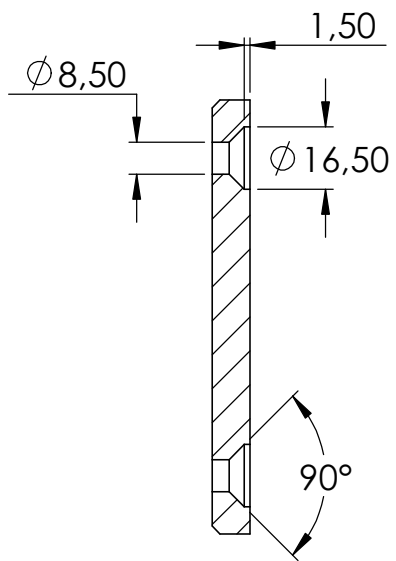
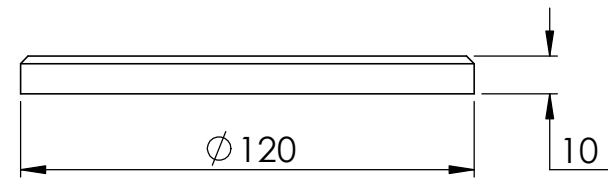
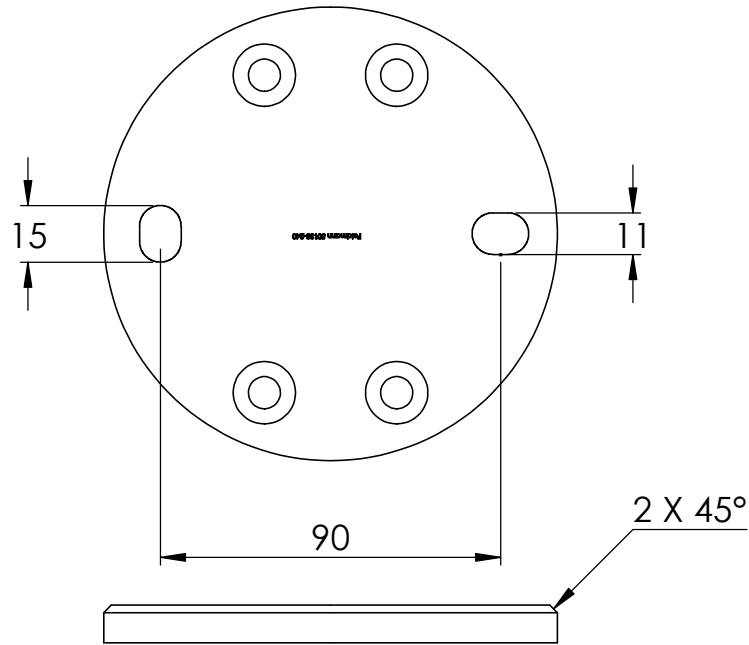

SCHNITT C-C

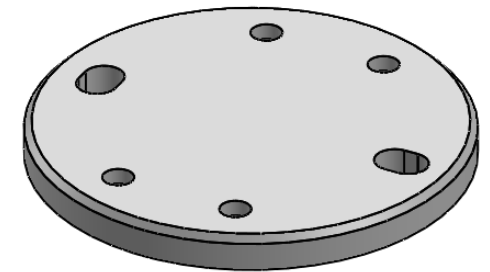
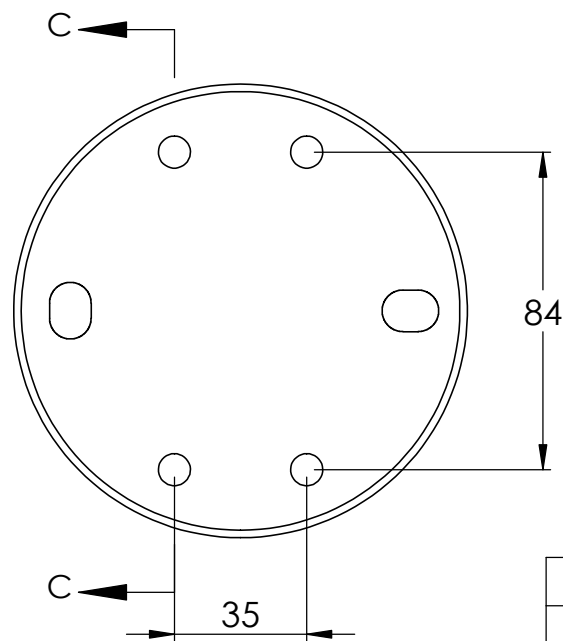

Name	Signatur	Datum	Artikelnummer	Oberfläche: Geschliffen Korn 240
Ch. Höfig	CH	02.09.2019	50138-240 Teil 1	
Werkstoff: 1.4301 (X5CrNi18-10)			Hersteller	Blattformat
			 Feldmann EDELSTAHL-ALUMINIUM-SCHMIEDEISEN	A4
Gewicht 0,831 kg		Massstab: 1:2	Version: 1	Blatt 4 von 6

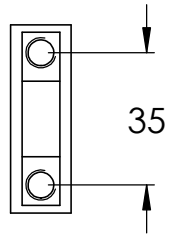

SCHNITT D-D

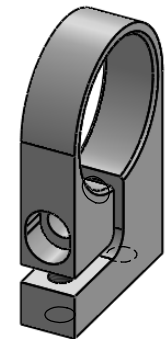
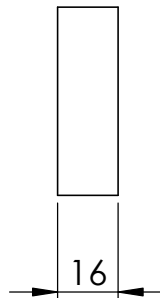
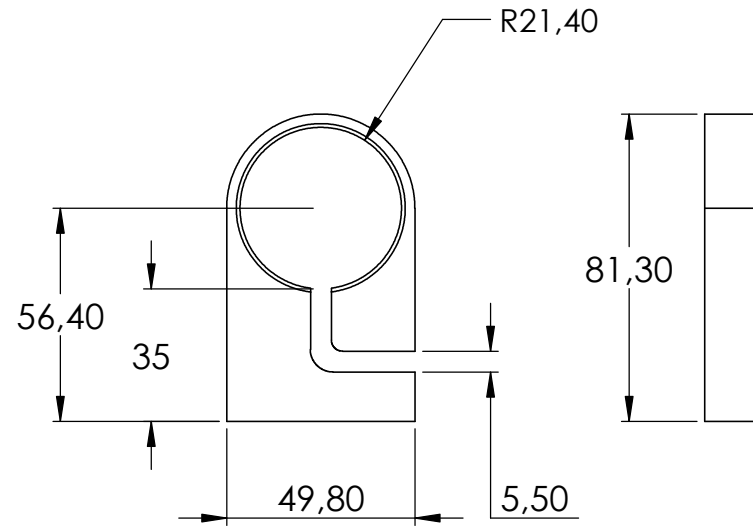
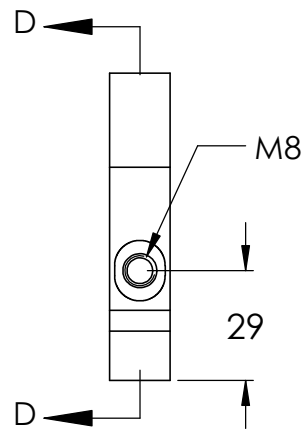
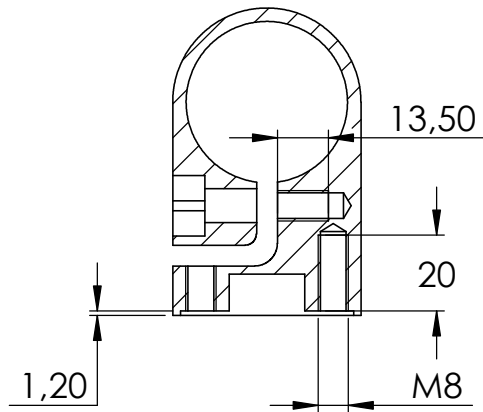

Name	Signatur	Datum	Artikelnummer	Oberfläche: Geschliffen Korn 240
Ch. Höfig	CH	02.09.2019	50138-240 Teil2	
Werkstoff: 1.4301 (X5CrNi18-10)			Hersteller	Blattformat
			 Feldmann EDELSTAHL-ALUMINIUM-SCHMIEDEISEN	A4
Gewicht 0,212 kg		Massstab: 1:2	Version: 1	Blatt 5 von 6

POS-NR.	BENENNUNG	MENGE
1	40541-240 Teil1	1
2	50138-240 Teil1	1
3	50138-240 Teil2	2
4	DIN 912 M8 x 30 --- 30S	2
5	DIN 7991 - M8 x 20 --- 20S	4

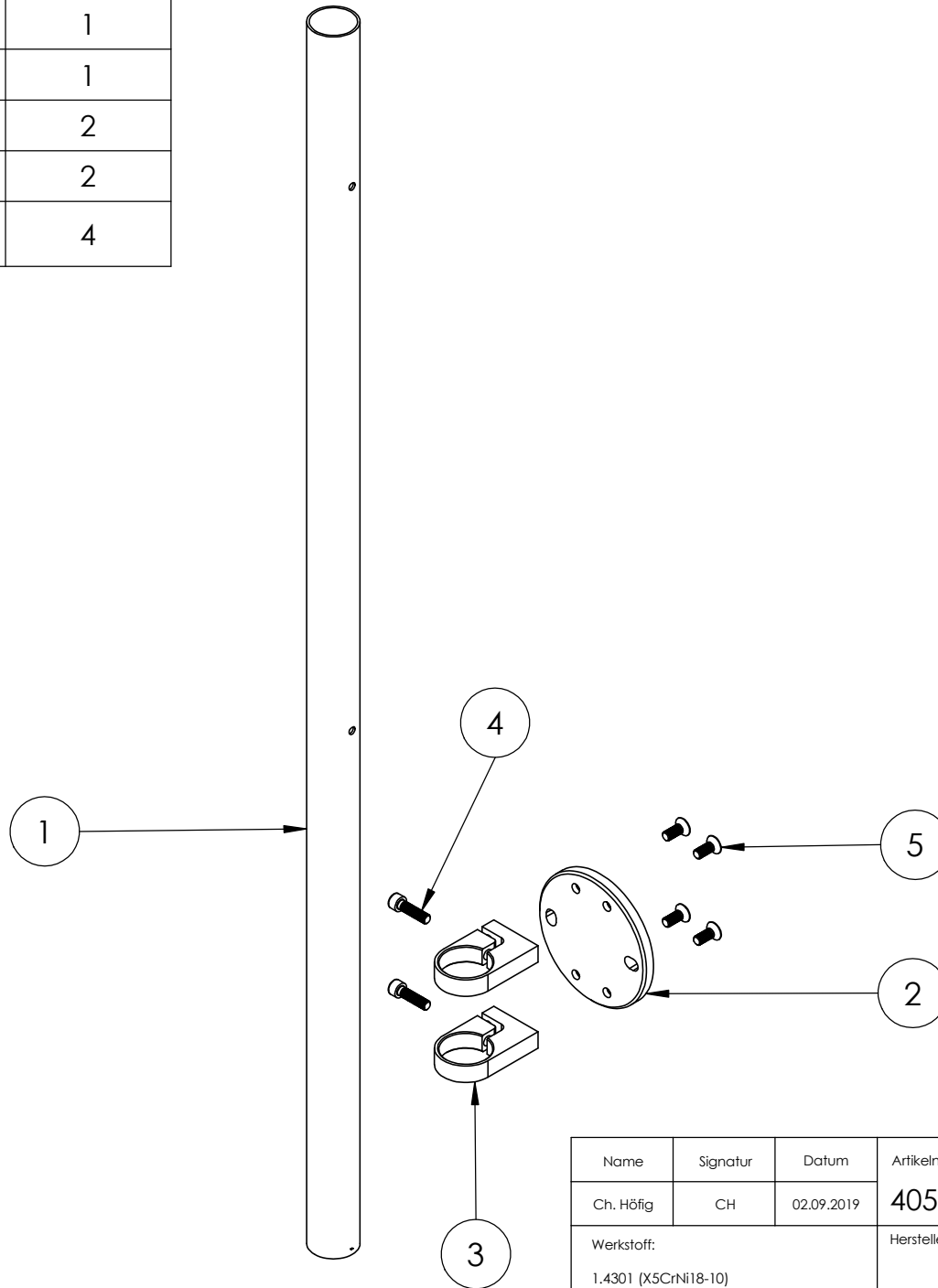

Name	Signatur	Datum	Artikelnummer	Oberfläche: Geschliffen Korn 240
Ch. Höfig	CH	02.09.2019	40541-240	
Werkstoff: 1.4301 (X5CrNi18-10)			Hersteller	Blattformat
			 Feldmann EDELSTAHL · ALUMINIUM · SCHMIEDEISEN	A4
Gewicht 3,649 kg		Massstab: 1:5,5	Version: 1	Blatt 6 von 6